

04/2023

# AUTOMATIC RIVETING MACHINES

The practical modular principle  
guarantees efficiency and quality



A member of **SFS** 

**GESIPA**<sup>®</sup>  





## ***GESIPA®-AUTOMATIC RIVETING MACHINES***

# GESIPA®-AUTOMATIC RIVETING MACHINES

Fully-automatic, practical, reliable



**GESIPA® automatic blind riveting systems are particularly designed for use in industrial production.**

For all applications that need a huge number of rivets to be set fast and efficiently investing in an automatic riveting system pays off already after a very short time. These systems can be operated very flexibly, be it manually, as part of a robot-controlled system or integrated into production lines. Nearly everything is possible with **GESIPA® GAV**.



The individual configuration of the system according to customer specifications and requirements provides a lot of options, and, of course, already existing systems can be upgraded.

Depending on the model, a GAV can set rivets from 2.4 mm to 8.0 mm in diameter which make these riveting units ideally suited for a wide range of applications and sectors. Up to 40 blind rivets can be set per minute depending on the type of application and model.

No special knowledge is required for operating the system. Already after short instruction workers will be able to operate the machines in the best possible way.

We are happy to offer more intensive training courses for operating staff so that maintenance can be done internally. Our maintenance and service contracts at attractive conditions provide a complete service package in order to ensure reliable, uninterrupted operation of production processes.

**Please ask for further advice – we will be pleased to submit an interesting offer.**

# THE PRACTICAL MODULAR PRINCIPLE

The practical modular principle guarantees efficiency and quality

GESIPA®'s fully-automatic blind rivet processing systems are constructed to meet the customer's special production environment. All factors, such as workplace design, production Type, application, securing of flawless work processes, integration into the sequential organisation and also process documentation for safety-relevant parts, are taken into consideration.

**GAV** are therefore available with various pistol models, hose length packages, special accessories for various rivet dimensions and production requirements. This results in a large variety of models and a high level of efficiency thanks to the solutions that are adapted to meet requirements.

The GAV can be integrated into the system or operated independently. If the application changes, the system can be quickly and easily adapted to the new environment.

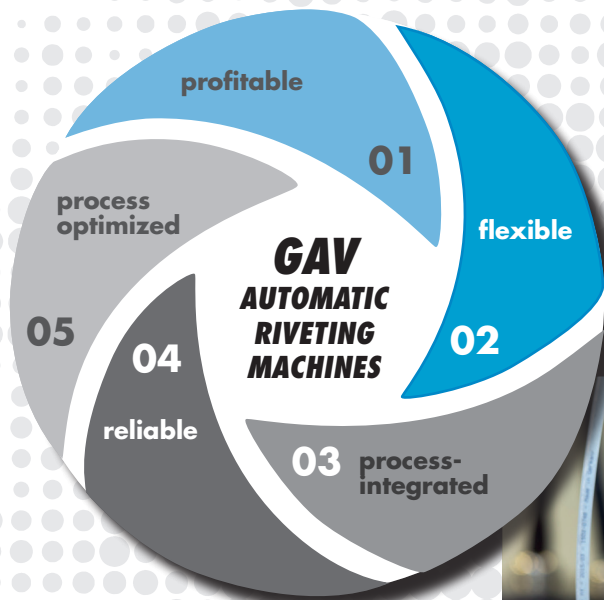

## Use by industry in robot-controlled applications

Both versions of the GAV 8000 can be integrated into robot systems. Industrial robots are used almost everywhere in the production environment. They can be programmed to carry out various movements and can therefore be used highly efficiently in combination with the GESIPA® rivet equipment.

With the controlled, fast and secure production processes it is possible to achieve the following benefits by using a fully-automatic GAV combined with a multi-axe robot:

- **First rate precision**
- **High efficiency**
- **Short cycle times**
- **High flexibility**

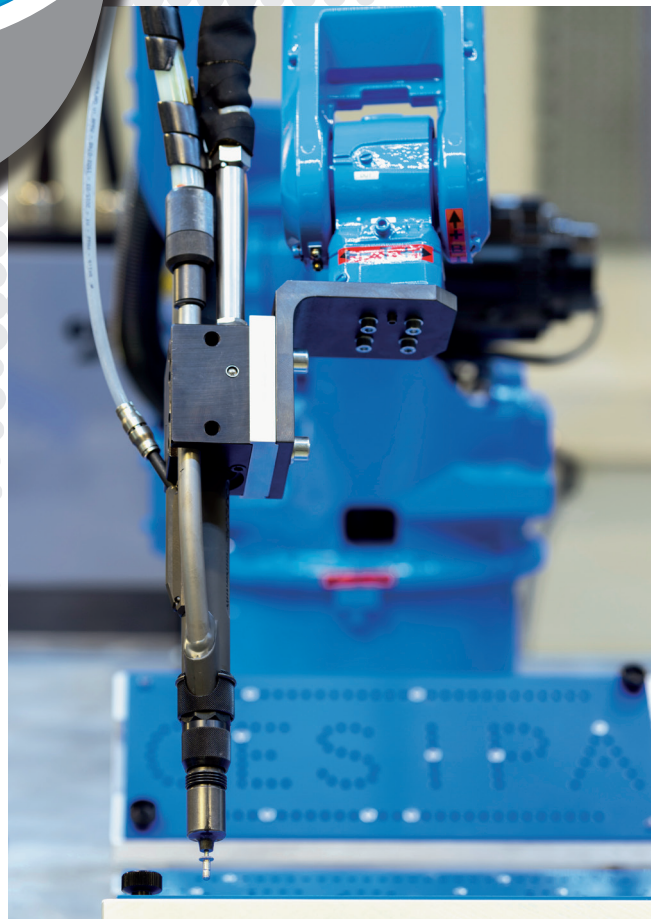

# OVERVIEW OF GESIPA®-AUTOMATIC RIVETING MACHINES



## **GAV 8000 eco**

GAV 8000 eco is the basic model of GESIPA® fully automatic setting tools. It provides all advantages and is particularly suited for all applications that do not require setting process monitoring. Subsequent upgrading, however, is possible at any time.

## **GAV 8000 electronic**

The fully automatic blind riveting system GAV 8000 electronic does not only allow to save up to 50% in time and costs but also ensures reliable production processes with its integrated setting process monitoring. GAV 8000 electronic can either be operated as an individual system, as part of a robot-controlled system or integrated into a production line.

## **GAV HF**

GAV HF can be used in many different areas and covers a wide range of applications. GAV HF is a real specialist system and particularly suited for setting large rivets from 6 mm to 8 mm in diameter. In the truck/trailer, container and body in white production very often high-strength or structural blind rivets are used that can easily be set by GAV HF.



GAV HF



GAV 8000 electronic

GAV 8000 eco

# GAV 8000 ELECTRONIC

Fully automatic blind rivet system for industrial production  
with setting process monitoring

with setting  
process  
monitoring

## Working range

- 2.4 mm up to 6.4 mm Ø alu and copper
- Up to 6 mm Ø steel
- Up to 5 mm Ø stainless steel
- Up to flange diameter 11.4 mm
- Rivet body lengths above 30 mm
- Traction power up to 11,770 N at 6-7 bar air pressure

## Productivity and savings potential

- Cost effective from an annual quantity of around 500,000 blind rivets (in relation to the german market)
- Up to 50 % time and costs savings compared to standard blind rivet devices
- Rivet pistol has a large action radius thanks to the hose package that is up to 5.0 m in length (Standard length 3.75 m)
- No trained personnel required for operation
- Can be easily integrated into fully-automatic production systems
- Up to 40 blind rivets can be processed every minute

## System description

- Electronic system controls
- Intuitive menu guidance via navigation and function keys
- Function display
- Maintenance display and simple fault diagnosis
- Customer-specific software modification is possible
- Rivet mandrels are disposed of by vacuum system
- Spring loaded trigger system as an optional extra available
- Can be integrated into the system or operated independently
- Interface for external memory programmable control system (SPS) can be realised via the GESIPA® interface

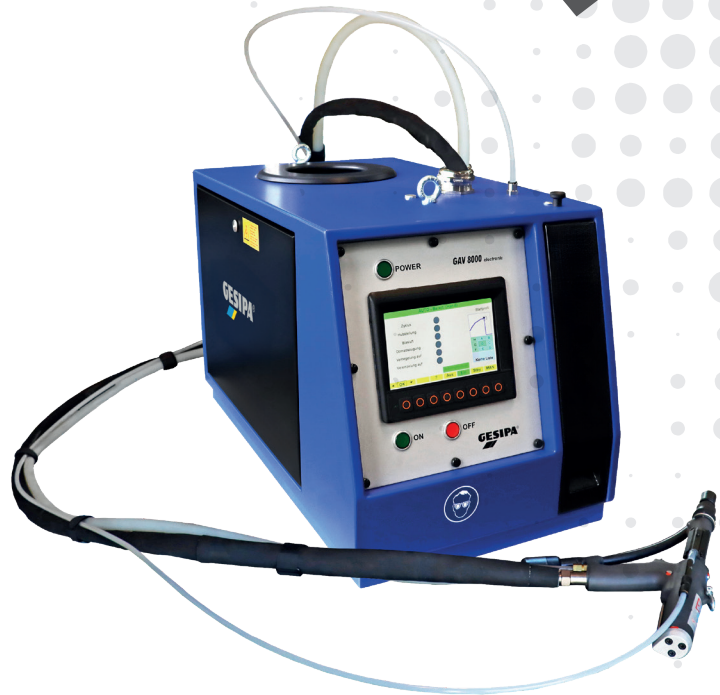

Advice and delivery time on request



# GAV 8000 ECO

Fully-automatic blind rivet processing system and cost-optimized variant of the GAV 8000 electronic **without setting process monitoring**

without setting  
process monitoring

## Working range

- 2.4 mm up to 6.4 mm Ø alu and copper
- Up to 6 mm Ø steel
- Up to 5 mm Ø stainless steel
- Up to flange diameter 11.4 mm
- Rivet body lengths above 30 mm
- Traction power up to 11,770 N at 6-7 bar air pressure



## Productivity and savings potential

- Up to 40 blind rivets can be processed every minute
- No trained personnel required for operation
- Can be easily integrated into fully-automatic production systems

Advice and delivery time on request

## System description

- Electronic system controls
- Intuitive menu guidance via navigation and function keys
- Function display
- Maintenance display and simple fault diagnosis
- Customer-specific software modification is possible
- Ideal for applications that do not require any process monitoring
- Rivet mandrels are disposed of by vacuum system
- Spring loaded trigger system as an optional extra available
- Can be integrated into the system or operated independently
- Interface for external memory programmable control system (SPS) can be realised via the GESIPA® interface

**Subsequent upgrade to GAV 8000 electronic possible in our Walldorf factory at extra price**



# SAFE AND SECURE – SETTING PROCESS MONITORING

The integrated GESIPA® quality management system guarantees precision and accuracy right from the very first production step through to the processed blind rivet.

## Blind rivet function documentation and setting process monitoring

The combination of the use of function-documented blind rivets and the use of the setting process monitoring function of the GAV 8000 electronic guarantees process-secure connections.



### Function documentation / Setting curve (1)

In addition to other parameters, the setting curve is measured using calibrated testing equipment for every batch of application-specific blind riveting. The measuring results of the shaft deformation, slip-in behaviour, mandrel break load and torque are compared to target values to ensure that the blind rivet in the application is deformed as required and creates a secure connection.

### Function documentation / Mandrel ejection force (2)

The remaining part of the mandrel enclosed in the set rivet is pressed out with the aid of a needle. The measured force can be used to determine whether the remaining part of the pin is properly locked and will not cause any rattling noises or fall out. The batch is only released if both these values are within tolerances.

The quality management system comprises of three areas:

- **Dimensional review**
- **Function test**
- **Setting process monitoring**

The dimensional review and the function test are carried out at GESIPA®, whilst the setting process is monitored during the riveting process at the customer's premises.

(1)

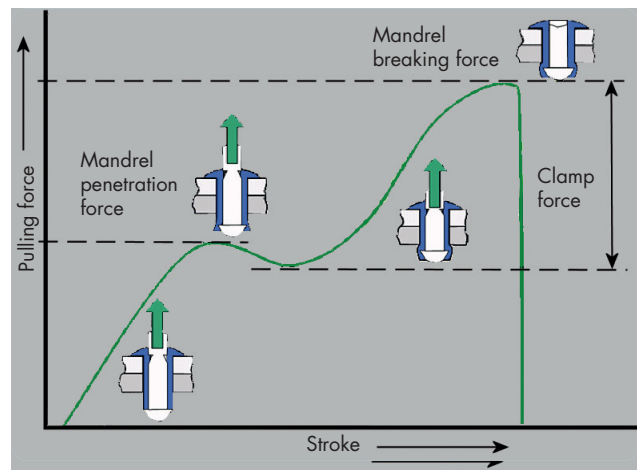

(2)

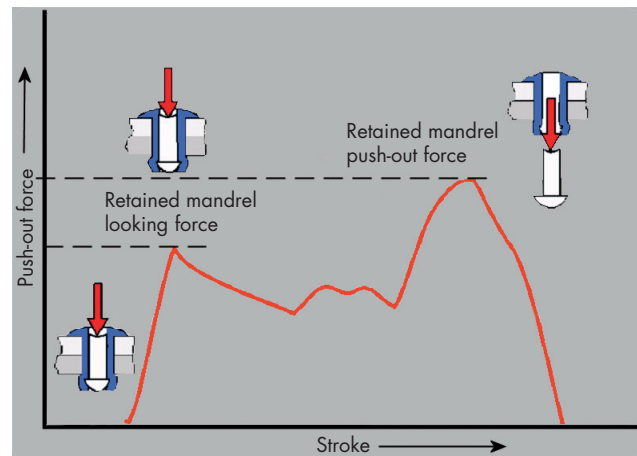

### Monitored process – Reliable connection

100% inspections of the riveting processes are required for safety-relevant applications for industrial processing of blind rivets. In this case, the fully-automatic rivet device GAV 8000 electronic allows application-compatible efficient solutions ranging from the basic system through to a system with a barcode scanner.

# THE CONCEPT TO THE INTEGRATED SETTING PROCESS MONITORING



The process monitoring system is an integral part of the GAV 8000 electronic.

It offers the following benefits:

- Optimum process security thanks to integrated quality concept
- Blind rivet-specific process monitoring
- System can be operated independently
- No memory-programmable control system (SPS) required to operate the device
- No system calibration required when system is exchanged
- Little installation effort required
- Interfaces to the control integratio

Display of a GAV 8000 electronic indicating the setting curve as part of the setting process monitoring

## Programming the setting process monitoring

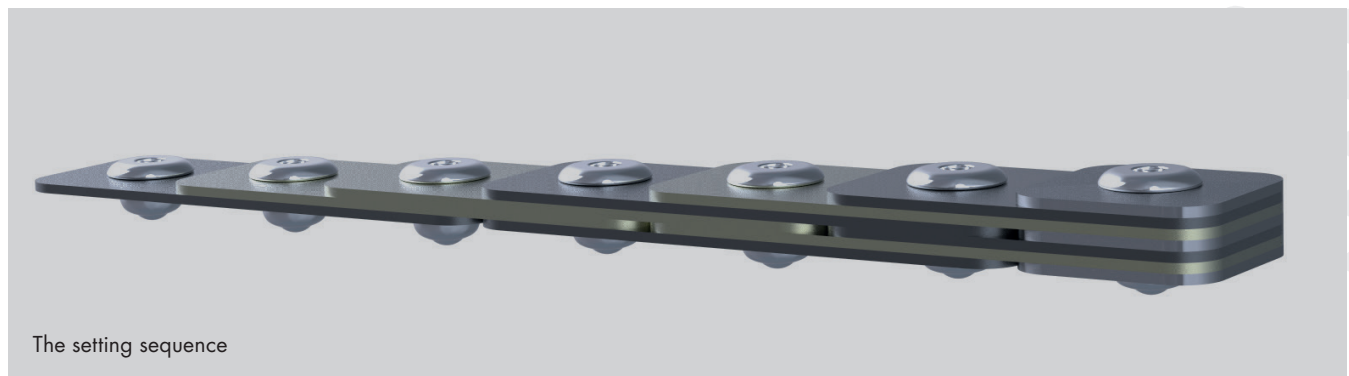

The setting sequence

### Step 1 Setting up blind rivet position-specific profiles

Recording and archiving of the relevant process parameters to create a blind rivet connection with reference process curves after defining the analysis window.

### Step 2 Generation of part-specific profile lists

Summary of the profile in the setting sequence as a control file for the process sequence and process assessment.

### Step 3 Operating the device

Online analysis and saving of the setting process data with process interruption if deviations are detected.

# ACCESSORIES FOR GAV 8000 ECO / GAV 8000 ELECTRONIC

Individual system configuration for each application case

## PISTOL VERSIONS

### Specific workstation configuration

For all GAV versions, three different setting pistol variants are available for the ideal configuration of the workstation.

For manual workstations, pistols are available as overhead versions with overhead hose assembly or standard pistols with floor-mounted hose assembly. Both versions are equipped with a balancer to ensure fatigue-free working. The robotic pistol has been developed exclusively for use in fully automatic production systems or robot-controlled systems. It is supplied from stock with corresponding drilled holes for easy installation. For further questions, please contact our Technical Sales team.

A setting pistol suitable for your application is supplied at time of delivery.



### STANDARD PISTOL Total length: 447 mm (+ SL nose)

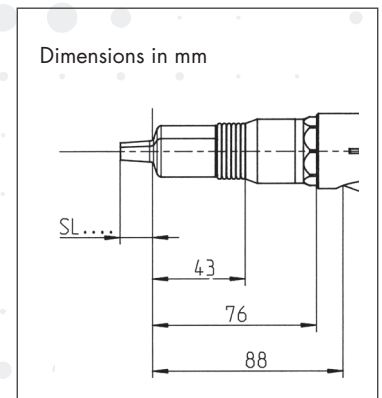
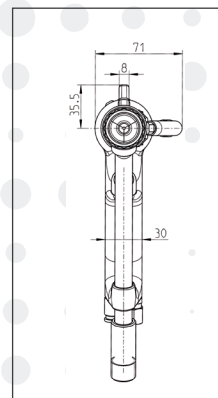

The standard pistol is primarily used for manual operator-controlled use.

### Advantages

- Can be used for vertical and horizontal riveting
- Inexpensive variant
- On request, it can be fitted with an extra handle to
- Improve ergonomics, in particular for applications
- Involving vertical riveting

**OVERHEAD PISTOL** Total length: 447 mm (+ SL nose)

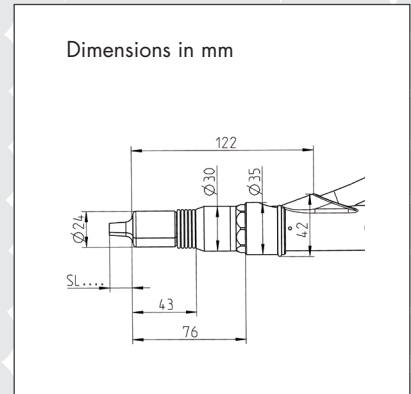
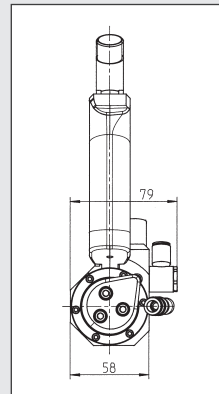

The overhead pistol can be used everywhere where the hose package is cumbersome or where it could come into contact with sensitive surfaces.

**Advantage**

- Available with contact pressure monitoring

**ROBOTIC PISTOL** Total length: 441 mm (+ SL nose)

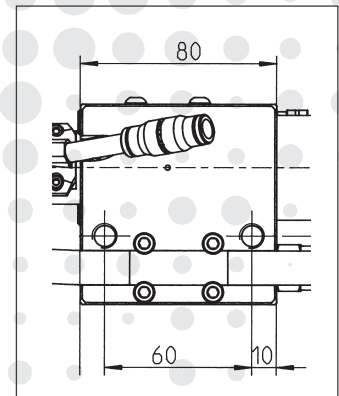
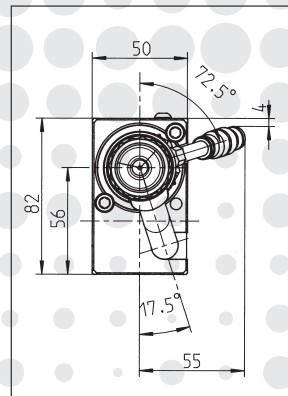
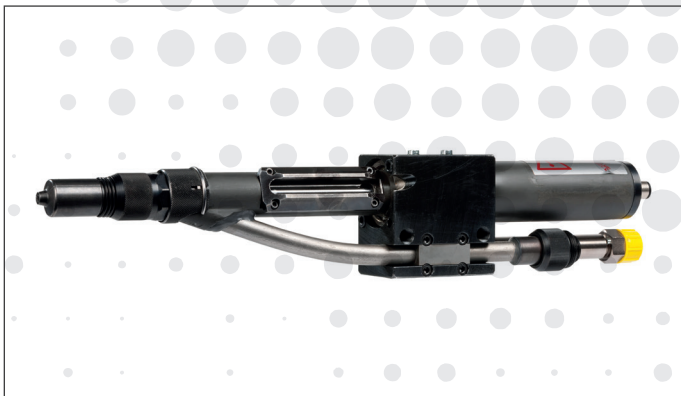

The robotic pistol has been developed primarily for use in fully automatic production applications/system (linear units/robots).

**Advantages**

- Ideal for integration in a production system
- On request, it can also be fitted with an extra handle (with trigger button) for vertical riveting so that it can be used manually

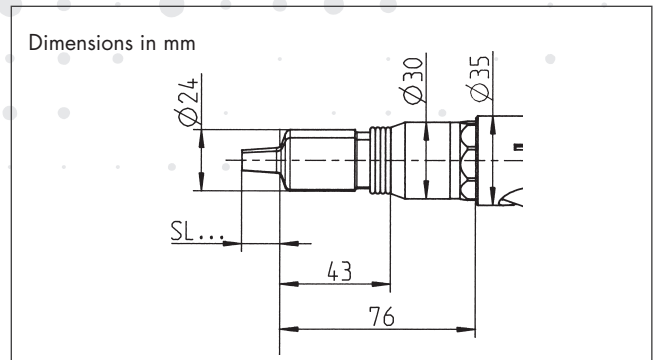

# ACCESSORIES GAV 8000 ECO / GAV 8000 ELECTRONIC

Individual system configuration for each application case

## Individual system configuration for each application case

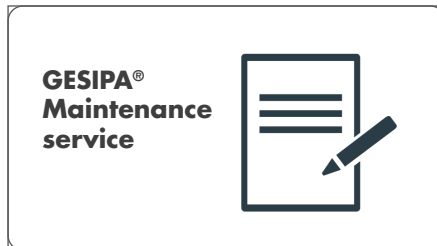

### Interface for connection to external control

The new GESIPA® interface developed by GESIPA® is based on an embedded PC system and provides 24 digital in and out control system ports, Ethernet connection via a RJ45 connector as well as status LEDs. Connection ports for a protocol converter supporting all common bus systems and for external storage media as well as a USB port for fast data transfer complete the features of the new interface. In addition, the GESIPA® interface has a process data-base for storing 250,000 of the most current process data (date, time, rivet position, process curve, analysis, etc.). Of course, the interface is backward compatible with its predecessor models.

### Extra handle for Robotic Pistol

As an additional option, the Robotic Pistol can also be supplied with an extra handle or with a extra double handle. So it cannot only be used in a fully automatic system but also manually.

### Electrical foot pedal

The electrical foot pedal is a good solution wherever applications require both hands to affix the parts that need to be riveted.

### Special length tube packages

A larger working radius can be achieved, e.g. for use on fully automatic production lines, by using packages of special hose lengths. These are available in various dimensions between 3.75 m and 5.0 m to meet the requirements of the various applications.

### GAV carriage

The trolley that has been specially designed for the GAV enables it to be mobile thereby allowing the workplace to be changed quickly and easily.

### GESIPA®-Balancer

For ergonomic and fatigue-free operation, suspending the pistol and the host pack is absolutely necessary. Here, the GESIPA®-Balancer provides the right solution.



### Maintenance service for your GESIPA® Blind Riveting System

Our maintenance and service contracts ensure that riveting systems always stay up-to-date and running which means smooth processes and huge production numbers in high quality. You can arrange a maintenance contract either immediately when buying a GESIPA® GAV or, of course, afterwards. We will recommend precise and fair maintenance intervals. You then decide, based on how often and to which extent your system is used, whether you would like to have maintenance carried out every 3 months, every 6 months or once per year. As an exclusive service for our customers who have signed a maintenance contract, only one-way travel expenses will be charged.

### GESIPA® Training – Always up-to-date with GESIPA®

To make sure that you and your employees are always up-to-date we offer training courses for your operating, maintenance and service staff either when purchasing a GESIPA® blind riveting system or afterwards. Training courses will be held by our experienced and competent service technicians either at our plant in Mörfelden-Walldorf or at your company. The date, place and scope of the training course are subject to individual agreement.

### Comparison of GAV 8000 eco and GAV 8000 electronic

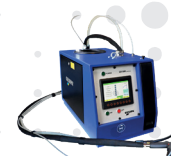
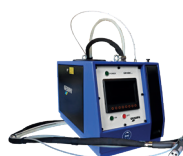

PROPERTIES	GAV 8000 eco	GAV 8000 electronic
Range of possible sizes 2.4 mm - 6.4 mm (Alu)	x	x
Up to 40 rivet settings per minute	x	x
Independent system operation possible	x	x
PLC control possible	x	x
Intelligent control – excellent process safety	x	x
Setting of all operating parameters via the display	x	x
Customer-specific software modification	x	x
Maintenance display	x	x
Power supply unit: Convenient automatic adjustment to all country-specific electricity networks thanks to wide range input	x	x
Simple update to the control possible by USB interface	x	x
Modern 7" display with high resolution (800x480 px), good contrasts and improved viewing angle dependencies	x	x
Process monitoring		x
Process parameter memory for up to 9,999 different parts		x
Online transfer of the process data		x
The last 1 million rivet processes are saved in the device		x



SFS Group Germany GmbH  
Division Riveting – GESIPA®  
Nordendstraße 13-39  
64546 Mörfelden-Walldorf  
T +49 6105 962 0  
info@gesipa.com  
**www.gesipa.com**

