

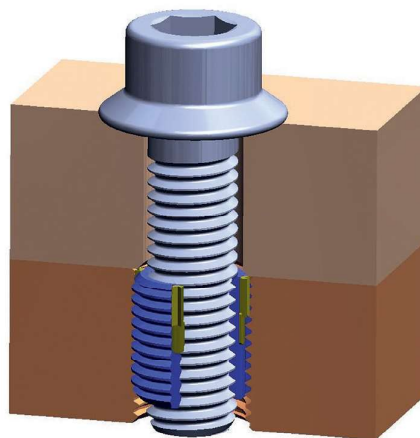

	Page
General Information	A-2
Features of KEENSERTS [®]	A-3 - A-4
Installation Instructions	A-5
KNCM Series (miniature inserts metric)	B-1
KNM Series (lightweight inserts metric)	B-2
KNHM Series (heavy duty inserts metric)	B-3 - B-4
KNCA Series (miniature inserts imperial)	C-1
KNJ Series (lightweight inserts imperial)	C-2 - C-3
KNHJ Series (heavy duty inserts imperial)	C-4 - C-7
KNHXHJ Series (extra heavy duty inserts imperial)	C-8 - C-11
KEENSERTS [®] POWER TOOLS	D-1
Features.....	D-2
Technical Data and Standards	D-3
Nosepieces	D-4
Installation procedure	D-5
Available nosepieces	D-6 – D-7
KEENSERTS [®] Hand Tools KNT Series.....	E-1
General Informations.....	E-3
Installation Process.....	E-4
Available Tool sizes.....	E-5
KEENSERTS [®] EPT1 POWER TOOL.....	F-1
Features.....	F-3
Technical Data and Standards	F-4
Nosepieces	F-5
Installation procedure	F-6
Available nosepieces	F-7 – F-8



The Camloc brand was established in 1937. Since that time our fastening systems have been successfully integrated into numerous applications within many different industries.

Our customers benefit from our more than 80 years of fastening experience.

We provide local support for innovative, high quality fastening systems supplied globally to the strictest environmental and working conditions.



IATF 16949:2016



ISO 14001:2015

Your Howmet Fastening Systems team

Disclaimer:

Parts listed are subject to technical changes. All dimensions in mm. All information is correct to the best of our knowledge at the time of printing. No liability for disadvantages caused by printing errors or false application.

Threaded Inserts

KEENSERTS® are high strength threaded inserts made from stainless steel 1.4305 or AISI303. They are passivated according to EN 2516 or AMS 2700. Our **KEENSERTS®** standard product range contains metric and imperial thread dimensions. Specials are available upon request.

KEENSERTS® can be used in alloys, light materials, steel and cast iron to give increased thread strength in these low strength materials. They are also be used for thread repair enabling the damaged thread to be replaced with the same size thread.

KEENSERTS® Solid configuration gives a high cycle life with multiple tightening and loosening of the bolt. Locking inserts have a dry film lubrication on the surface to protect the screw from galling.

KEENSERTS® have a positive mechanical lock against rotation and vibration when kees are installed. Kees are made from stainless steel AISI302.

KEENSERTS® have 2 or 4 pre-assembled kees depending on the size of the external thread. After installation of the kees into the parent material the assembly is positively locked in place.

Pull-out-strength for **KEENSERTS®**. Calculation is as follows:

Pull-out-strength(N) = shear engagement (mm²) x ultimate shear strength of parent material (N/mm²)
Shear engagement areas are shown on the **KEENSERTS®** data sheets, only valid for full installed **KEENSERTS®**.

Click here:

[Camloc KEENSERTS®](#) (Youtubelink)



Part-no. example:

The part-no. for metric **KEENSERTS®** are coded as follows:

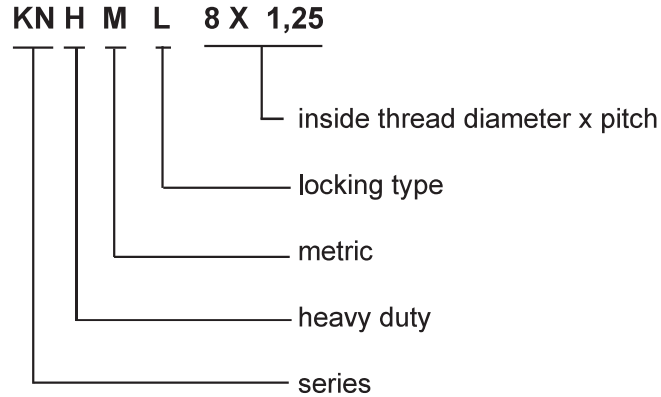

The part-no. for imperial **KEENSERTS®** are coded as follows:

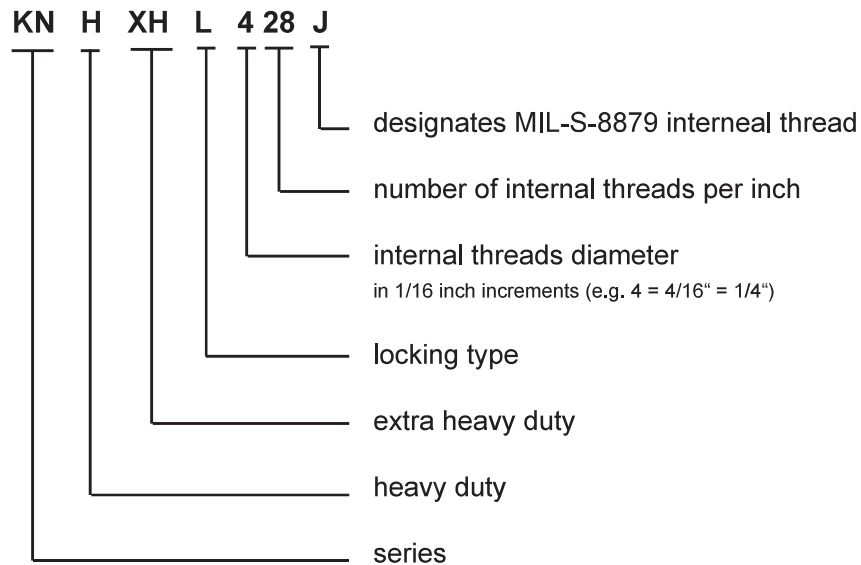

Installation:

- Drill - with standard drill
- Countersink - with cone countersink (80° - 100°)
- Thread - with standard tap
- Screw in - by hand or with installation tool
(see installation data pages B-1 to B-4)
- Lock in Place - drive the kees into place by hand
or in a press with the appropriate
installation tool

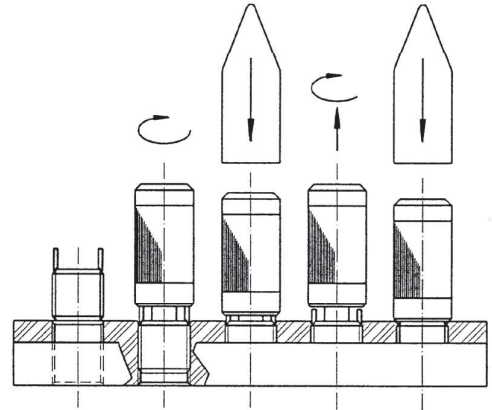

Installation depth of the **KEENSERTS®** is determined by the pre-assembled kees.
The installed depth of the **KEENSERTS®** is based on the depth of the countersink.

Installation in hard materials

For very hard materials with a hardness greater than 30 HRC or 300 Vickers it is necessary to pre-broach the slots for the kees. The first step is to mark the position of the kees on the parent material. To do this wind the **KEENSERTS®** in until the kees touch the surface of the parent material.

Mark the positions of the kees and unwind the **KEENSERTS®**.

Then line up the blades of the broaching tool with the marked positions and push it in with a hammer or under a press, remove the tool and install the **KEENSERTS®**.

In some cases it may be necessary to run the tap back down the hole to clear out any burrs.
Available for external metrical thread M5 and up and external imperial thread 1/4" and up.



Removal:

1. Drilling
Dimensions see pages B1 to B4
2. Deflect kees inward and break off
3. Remove insert with E-Z out type tool
4. Insert new **KEENSERTS®** as before

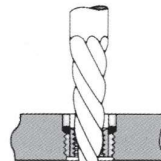
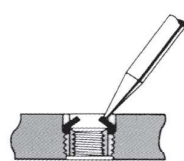
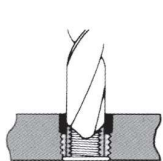

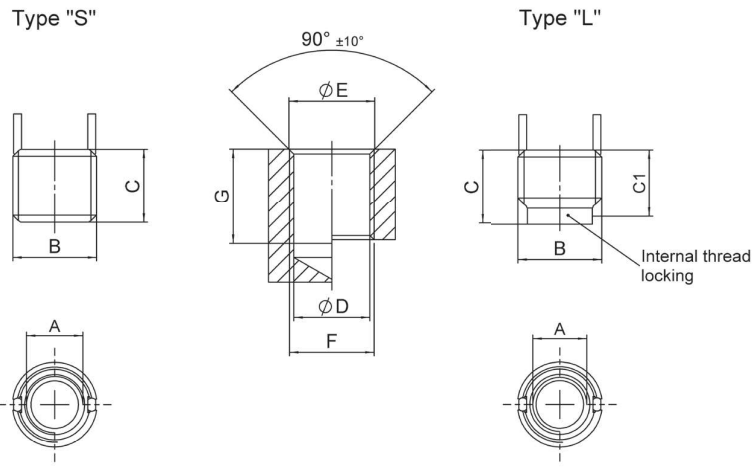

C1 = max. distance to end of thread lock

Part-no.		Dimensions				
Standard type "S"	Locking type "L"	Thread A Ø A class 5H	Thread B Ø B class 4h	Shear engagement mm ²	C ± 0,25	C1
KNCM2X0,4		M2X0,4	M4X0,7	16,5	3	2,2
	KNCML2X0,4			10,3		
KNCM2,5X0,45		M2,5X0,45	M4,5X0,75	26,5	3,8	2,7
	KNCML2,5X0,45			15,9		
KNCM3X0,5		M3X0,5	M5X0,8	33,1	4,25	3,1
	KNCML3X0,5			21,4		
KNCM4X0,7		M4X0,7	M6X0,75	58,4	5,25	4,1
	KNCML4X0,7			42,9		

Part-no.	Installation dimensions				Hand installation tool part-no.	Removal dimensions	
	Ø D modified tap drill Ø	Ø E counter- sink Ø + 0,25	Thread F			Drill	
			Ø F class 6H	G min.		Ø	Depth
KNCM2X0,4	3,4 +0,080 -0,025	4,1	M4X0,7	4,0	KRTM2-01	2,8	2,00
KNCML2X0,4							
KNCM2,5X0,45	3,9 +0,080 -0,025	4,6	M4,5X0,75	5,0	KRTM2,5-01	3,0	2,00
KNCML2,5X0,45							
KNCM3X0,5	4,4 +0,080 -0,025	5,1	M5X0,8	5,5	KRTM3-01	3,5	2,25
KNCML3X0,5							
KNCM4X0,7	5,5 +0,080 -0,025	6,1	M6X0,75	6,5	KRTM4-01	4,6	2,50
KNCML4X0,7							

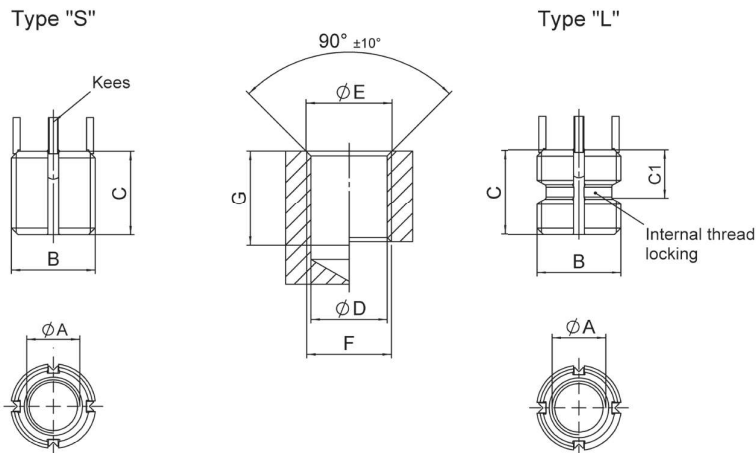

Kees:
Inserts with internal thread size of M6 and under are furnished with 2 locking kees
Inserts with internal thread size of M8 and above are furnished with 4 locking kees

C1 = max. distance to end of thread lock

Part-no.		Dimensions				
Standard type "S"	Locking type "L"	Thread A Ø A class 5H	Thread B Ø B class 4h	Shear engagement mm ²	C ± 0,30	C1
KNM5X0,8		M5X0,8	M8X1,25	104,9	8	7,6
	KNML5X0,8			83,1		
KNM6X1,0		M6X1,0	M10X1,25	177,7	10	8,2
	KNML6X1,0			152,7		
KNM8X1,25		M8X1,25	M12X1,25	266,7	12	9,5
	KNML8X1,25			242,5		
KNM10X1,5		M10X1,5	M14X1,5	341,6	14	10,0
	KNML10X1,5			316,4		
KNM12X1,75		M12X1,75	M16X1,5	470,2	16	11,2
	KNML12X1,75			441,4		

Part-no.	Installation dimensions					Removal dimensions	
	Ø D modified tap drill Ø	Ø E counter- sink Ø + 0,25	Thread F		Hand installation tool part-no.	Drill	
			Ø F class 6H	G min.		Ø	Depth
KNM5X0,8	6,90 +0,100 -0,025	8,25	M8X1,25	9,5	KRTM5-01/ KNT01-M5X0,8AU	5,5	4,00
KNML5X0,8							
KNM6X1,0	8,80 +0,100 -0,025	10,25	M10X1,25	11,5	KRTM6-01/ KNT01-M6X1,0AU	7,5	4,75
KNML6X1,0							
KNM8X1,25	10,80 +0,100 -0,025	12,25	M12X1,25	13,5	KRTM8-01/ KNT01-M8X1,25AU	9,5	4,75
KNML8X1,25							
KNM10X1,5	12,80 +0,130 -0,025	14,25	M14X1,5	15,5	KRTM10-01/ KNT01-M10X1,5AU	11,5	4,75
KNML10X1,5							
KNM12X1,75	14,75 +0,130 -0,025	16,25	M16X1,5	17,5	KRTM12-01/ KNT01-M12X1,75AU	13,5	4,75
KNML12X1,75							

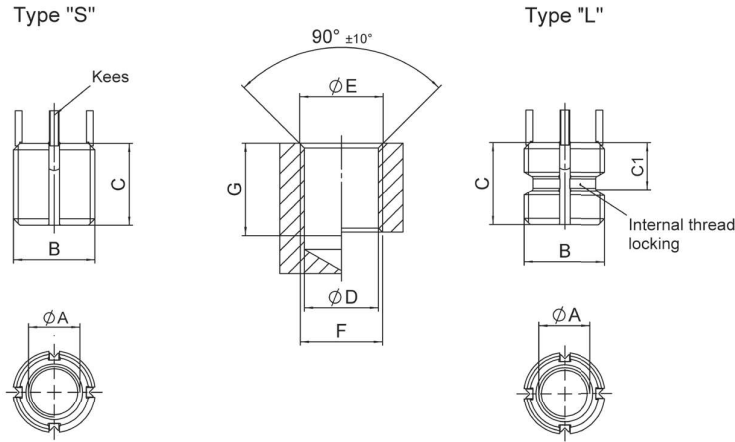

Kees:
Inserts with internal thread size of M6 and under are furnished with 2 locking kees
Inserts with internal thread size of M8 and above are furnished with 4 locking kees

C1 = max. distance to end of thread lock

Part-no.		Dimensions				
Standard type "S"	Locking type "L"	Thread A Ø A class 5H	Thread B Ø B class 4h	Shear engagement mm ²	C ± 0,30	C1
KNHM4X0,7	KNHML4X0,7	M4X0,7	M8X1,25	104,9	8	8,0
				83,1		
KNHM5X0,8	KNHML5X0,8	M5X0,8	M10X1,25	177,1	10	8,7
				152,7		
KNHM6X1,0	KNHML6X1,0	M6X1,0	M12X1,25	266,7	12	9,5
				242,5		
KNHM8X1,25	KNHML8X1,25	M8X1,25	M14X1,5	341,6	14	10,0
				316,4		
KNHM10X1,5	KNHML10X1,5	M10X1,5	M16X1,5	470,2	16	10,0
				441,4		
KNHM12X1,75	KNHML12X1,75	M12X1,75	M18X1,5	608,5	18	10,7
				561,8		

Part-no.	Installation dimensions					Removal dimensions	
	Ø D modified tap drill Ø	Ø E counter- sink Ø + 0,25	Thread F		Hand installation tool part-no.	Drill	
			Ø F class 6H	G min.		Ø	Depth
KNHM4X0,7	6,90 ^{+0,100} _{-0,025}	8,25	M8X1,25	9,5	KRTM4-02 / KNT01-HM4X0,7AU	5,5	4,00
KNHML4X0,7							
KNHM5X0,8	8,80 ^{+0,100} _{-0,025}	10,25	M10X1,25	12,5	KRTM5-02 / KNT01-HM5X0,8AU	7,5	4,75
KNHML5X0,8							
KNHM6X1,0	10,80 ^{+0,100} _{-0,025}	12,25	M12X1,25	14,5	KRTM6-02 / KNT01-HM6X1,0AU	9,5	4,75
KNHML6X1,0							
KNHM8X1,25	12,80 ^{+0,130} _{-0,025}	14,25	M14X1,5	16,5	KRTM8-02 / KNT01-HM8X1,25AU	11,5	4,75
KNHML8X1,25							
KNHM10X1,5	14,75 ^{+0,130} _{-0,025}	16,25	M16X1,5	18,5	KRTM10-02 / KNT01-HM10X15AU	13,5	4,75
KNHML10X1,5							
KNHM12X1,75	16,75 ^{+0,130} _{-0,025}	18,25	M18X1,5	20,5	KRTM12-02 / KNT01-HM12X1,75AU	15,5	4,75
KNHML12X1,75							

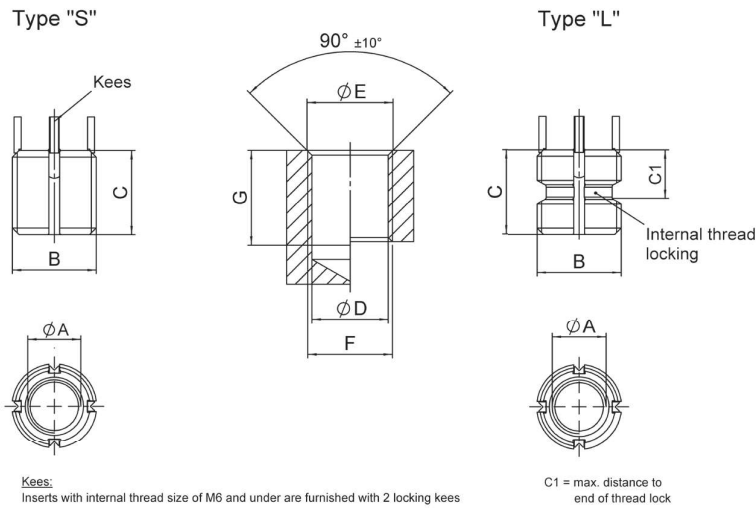

Part-no.		Dimensions				
Standard type "S"	Locking type "L"	Thread A Ø A class 5H	Thread B Ø B class 4h	Shear engagement mm ²	C ± 0,30	C1
KNHM14X2,0		M14X2,0	M20X1,5	770,5	20	12,4
	KNHML14X2,0			724,4		
KNHM16X2,0		M16X2,0	M22X1,5	896,8	22	12,4
	KNHML16X2,0			855,2		
KNHM18X1,5		M18X1,5	M24X1,5	1084,4	24	16,8
	KNHML18X1,5			1051,5		
KNHM20X2,5		M20X2,5	M30X2,0	1774,3	30	17,5
	KNHML20X2,5			1736,4		
KNHM24X3,0		M24X3,0	M33X2,0	2189,4	33	19,0
	KNHML24X3,0			2161,9		

Part-no.	Installation dimensions				Hand installation tool part-no.	Removal dimensions	
	Ø D modified tap drill Ø	Ø E counter-sink Ø + 0,25	Thread F			Drill	
			Ø F class 6H	G min.		Ø	Depth
KNHM14X2,0 KNHML14X2,0	18,75 ^{+0,130} _{-0,025}	20,25	M20X1,5	22,5	KRTM14-02 / KNT03- HM14X2,0AU	17,50	4,75
KNHM16X2,0 KNHML16X2,0	20,50 ^{+0,130} _{-0,025}	22,25	M22X1,5	24,5	KRTM16-02 / KNT03- HM16X2,0AU	17,75	6,35
KNHM18X1,5 KNHML18X1,5	22,50 ^{+0,130} _{-0,025}	24,25	M24X1,5	26,5	KRTM18-02 / KNT03- HM18X1,5AU	19,75	6,35
KNHM20X2,5 KNHML20X2,5	28,00 ^{+0,130} _{-0,025}	30,25	M30X2,0	34,5	KRTM20-02 / KNT03- HM20X2,5AU	25,75	6,35
KNHM24X3,0 KNHML24X3,0	31,00 ^{+0,130} _{-0,025}	33,25	M33X2,0	37,5	KRTM24-02 / KNT03- HM24X3,0AU	28,75	6,35

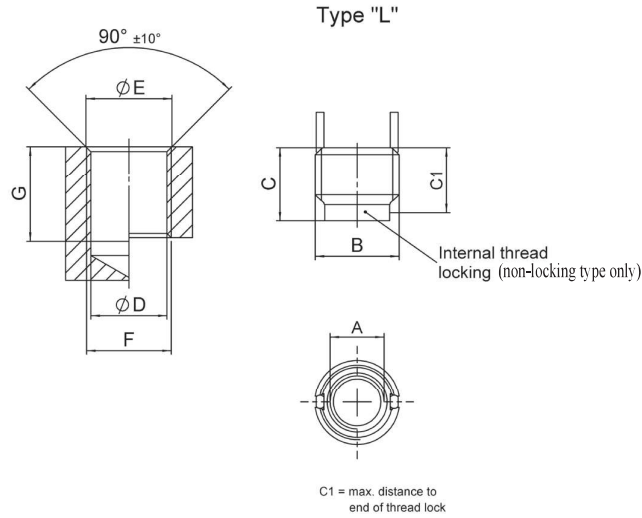

Part-no.		Dimensions				
Standard type "S"	Locking type "L"	Thread A Ø A	Thread B Ø B	Shear engagement inch ² (mm ²)	C inch (mm)	C1 inch (mm)
KNCA0256J		2-56" UNCJ-3B	8-32" UNC-3A	0,0157 (10,1)	0,12 (3,05)	0,088 (2,24)
KNCA0440J		4-40" UNCJ-3B	10-32" UNF-2A	0,0302 (19,5)	0,17 (4,32)	0,125 (3,18)
	KNCAL0440J			0,0302 (19,5)		
KNC0632J		6-32" UNCJ-3B	12-28" UNF-2A	0,0329 (21,2)	0,17 (4,32)	0,125 (3,18)
	KNCL0632J			0,0329 (21,2)		
KNCA0832J		8-32" UNCJ-3B	1/4-28" UNF-2A	0,0669 (43,2)	0,22 (5,59)	0,175 (4,45)
	KNCAL0832J			0,0669 (43,2)		

Part-no.	Installation dimensions				Hand installation tool part-no.	Removal dimensions	
	Ø D modified tap drill Ø inch	Ø E counter- sink Ø inch	Thread F			Drill	
			Ø F	G min. inch (mm)		Ø inch (mm)	Depth inch (mm)
KNCA0256J	.134 ^{+0,003} -0,001	.166 ^{+0,001} -0,000	8-32 UNC-2B	0,140 (3,56)	TKNC02	0,133 (2,87)	1/16 (1,59)
KNCA0440J	.161 ^{+0,003} -0,001	.194 ^{+0,001} -0,000	10-32 UNF-2B	0,160 (4,06)	TKNC04	0,136 (3,45)	3/32 (2,38)
KNCAL0440J							
KNC0632J	.187 ^{+0,003} -0,001	.220 ^{+0,001} -0,000	12-28 UNF-2B	0,160 (4,06)	TKNC06	0,159 (4,04)	3/32 (2,38)
KNCL0632J							
KNCA0832J	.228 ^{+0,003} -0,001	.225 ^{+0,001} -0,000	1/4-28 UNF-2B	0,210 (5,33)	TKNC08	0,199 (5,05)	1/8 (3,18)
KNCAL0832J							

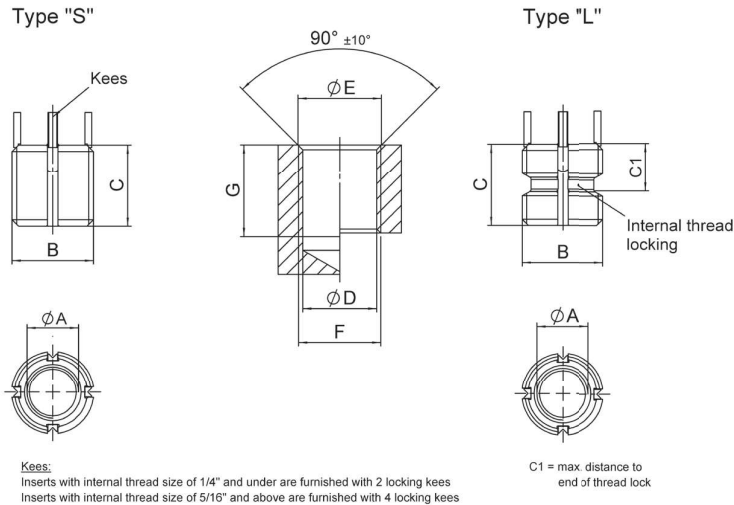

Part-no.		Dimensions				
Standard type "S"	Locking type "L"	Thread A Ø A class 3B	Thread B Ø B class 2A mod.	Shear engagement inch ² (mm ²)	C inch (mm)	C1 inch (mm)
KN1032J		10-32	5/16-18	0,1517 (97,9)	0,31 (7,87)	
	KNL1032J			0,0945 (60,9)		0,31 (7,87)
KN1024J		10-24	5/16-18	0,1517 (97,9)	0,31 (7,87)	
	KNL1024J			0,0945 (61,0)		0,31 (7,87)
KN428J		1/4-28	3/8-16	0,2371 (153,0)	0,37 (9,40)	
	KNL428J			0,1726 (111,4)		0,33 (8,38)
KN420J		1/4-20	3/8-16	0,2371 (153,0)	0,37 (9,40)	
	KNL420J			0,1726 (111,4)		0,36 (9,14)
KN524J		5/16-24	7/16-14	0,3049 (196,7)	0,43 (10,9)	
	KNL524J			0,2321 (149,7)		0,34 (8,64)
KN518J		5/16-18	7/16-14	0,3049 (196,7)	0,43 (10,9)	
	KNL518J			0,2321 (149,7)		0,37 (9,40)

Part-no.	Installation dimensions				Hand installation tool part-no.	Removal dimensions	
	Ø D modified tap drill Ø inch	Ø E countersink Ø inch +0,01 (mm)	Thread F			Drill	
			Ø F class 2B	G min. inch (mm)		Ø inch (mm)	Depth inch (mm)
KN1032J	0,272 (6,91)	0,323 (8,20)	5/16-18	0,37 (9,4)	TD1032L	7/32 (5,56)	5/32 (3,97)
KNL1032J							
KN1024J	0,272 (6,91)	0,323 (8,20)	5/16-18	0,37 (9,4)	TD1024L	7/32 (5,56)	5/32 (3,97)
KNL1024J							
KN428J	0,332 (8,43)	0,385 (9,78)	3/8-16	0,43 (10,9)	TD428L	9/32 (7,14)	3/16 (4,76)
KNL428J							
KN420J	0,332 (8,43)	0,385 (9,78)	3/8-16	0,43 (10,9)	TD420L	9/32 (7,14)	3/16 (4,76)
KNL420J							
KN524J	0,397 (10,08)	0,447 (11,35)	7/16-14	0,50 (12,7)	TD524L	11/32 (8,73)	3/16 (4,76)
KNL524J							
KN518J	0,397 (10,08)	0,447 (11,35)	7/16-14	0,50 (12,7)	TD518L	11/32 (8,73)	3/16 (4,76)
KNL518J							

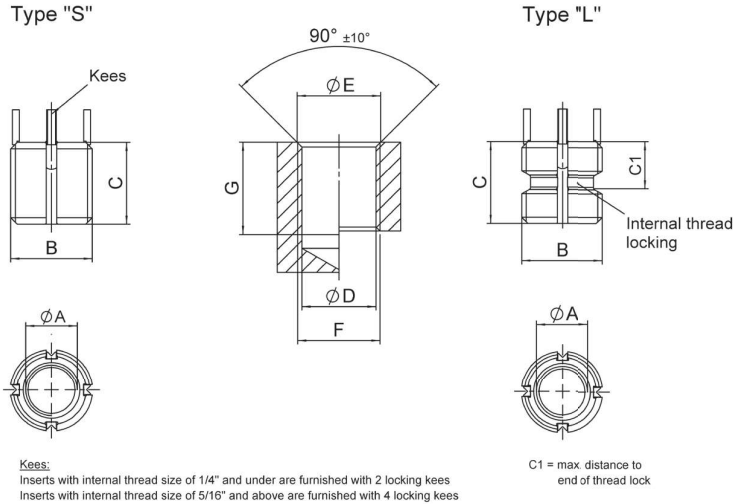

Part-no.		Dimensions				
Standard type "S"	Locking type "L"	Thread A Ø A class 3B	Thread B Ø B class 2A mod.	Shear engagement inch ² (mm ²)	C inch (mm)	C1 inch (mm)
KN624J		3/8-24	1/2-13	0,4299 (277,4)	0,50 (12,7)	0,36 (9,14)
	KNL624J			0,3366 (217,2)		
KN616J		3/8-16	1/2-13	0,4299 (277,4)	0,50 (12,7)	0,40 (10,16)
	KNL616J			0,3366 (217,2)		
KN720J		7/16-20	9/16-12	0,5665 (365,5)	0,56 (14,2)	0,41 (10,41)
	KNL720J			0,4606 (297,2)		
KN714J		7/16-14	9/16-12	0,5665 (365,5)	0,56 (14,2)	0,45 (11,43)
	KNL714J			0,4606 (297,2)		
KN820J		1/2-20	5/8-11	0,7175 (462,9)	0,62 (15,6)	0,42 (10,67)
	KNL820J			0,5906 (381,0)		
KN813J		1/2-13	5/8-11	0,7175 (462,9)	0,62 (15,6)	0,47 (11,94)
	KNL813J			0,5906 (381,0)		

Part-no.	Installation dimensions				Hand installation tool part-no.	Removal dimensions	
	Ø D modified tap drill Ø inch	Ø E countersink Ø inch +0,01 (mm)	Thread F			Drill	
			Ø F class 2B	G min. inch (mm)		Ø inch (mm)	Depth inch (mm)
KN624J	0,453 (11,51)	0,510 (12,95)	1/2-13	0,56 (14,2)	TD624L	13/32 (10,32)	3/16 (4,76)
KNL624J							
KN616J	0,453 (11,51)	0,510 (12,95)	1/2-13	0,56 (14,2)	TD616L	13/32 (10,32)	3/16 (4,76)
KNL616J							
KN720J	0,516 (13,11)	0,572 (14,53)	9/16-12	0,62 (15,7)	TD720L	15/32 (11,91)	3/16 (4,76)
KNL720J							
KN714J	0,516 (13,11)	0,572 (14,53)	9/16-12	0,62 (15,7)	TD714L	15/32 (11,91)	3/16 (4,76)
KNL714J							
KN820J	0,578 (14,68)	0,635 (16,13)	5/8-11	0,68 (17,3)	TD820L	17/32 (13,49)	3/16 (4,76)
KNL820J							
KN813J	0,578 (14,68)	0,635 (16,13)	5/8-11	0,68 (17,3)	TD813L	17/32 (13,49)	3/16 (4,76)
KNL813J							



Type "S"

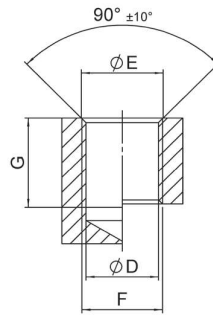
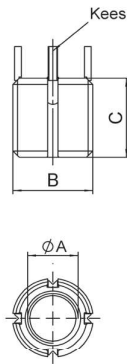

Type "L"

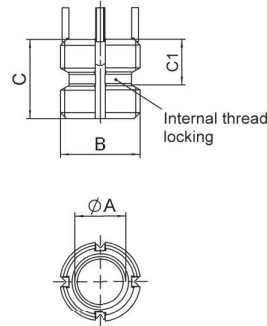

Kees:
Inserts with internal thread size of 1/4" and under are furnished with 2 locking kees
Inserts with internal thread size of 5/16" and above are furnished with 4 locking kees

C1 = max. distance to end of thread lock

Part-no.		Dimensions				
Standard type "S"	Locking type "L"	Thread A Ø A class 3B	Thread B Ø B class 2A mod.	Shear engagement inch ² (mm ²)	C inch (mm)	C1 inch (mm)
KNH0832J	KNHL0832J	8-32	5/16-18	0,1517 (97,87)	0,31 (7,87)	0,29 (7,37)
				0,0945 (60,97)		
KNH1032J	KNHL1032J	10-32	3/8-16	0,1901 (122,7)	0,31 (7,87)	0,31 (7,87)
				0,1156 (74,6)		
KNH1024J	KNHL1024J	10-24	3/8-16	0,1901 (122,7)	0,31 (7,87)	0,31 (7,87)
				0,1156 (74,6)		
KNH428J	KNHL428J	1/4-28	7/16-14	0,2842 (183,4)	0,37 (9,40)	0,33 (8,38)
				0,1970 (127,1)		
KNH420J	KNHL420J	1/4-20	7/16-14	0,2842 (183,4)	0,37 (9,40)	0,33 (8,38)
				0,1970 (127,1)		
KNH524J	KNHL524J	5/16-24	1/2-13	0,3588 (231,5)	0,43 (10,9)	0,34 (8,64)
				0,2608 (168,3)		

Part-no.	Installation dimensions					Removal dimensions	
	Ø D modified tap drill Ø inch	Ø E countersink Ø inch +0,01 (mm)	Thread F		Hand installation tool part-no.	Drill	
			Ø F class UNC-2B	G min. inch (mm)		Ø inch (mm)	Depth inch (mm)
KNH0832J	0,272 (6,91)	0,323 (8,20)	5/16-18	0,37 (9,4)	THD0832L	7/32 (5,56)	1/8 (3,18)
KNHL0832J							
KNH1032J	0,332 (8,43)	0,385 (9,78)	3/8-16	0,37 (9,4)	THD1032L	9/32 (7,14)	1/8 (3,18)
KNHL1032J							
KNH1024J	0,332 (8,43)	0,385 (9,78)	3/8-16	0,37 (9,4)	THD1024L	9/32 (7,14)	1/8 (3,18)
KNHL1024J							
KNH428J	0,397 (10,08)	0,447 (11,35)	7/16-14	0,43 (10,9)	THD428L	11/32 (8,73)	3/16 (4,76)
KNHL428J							
KNH420J	0,397 (10,08)	0,447 (11,35)	7/16-14	0,43 (10,9)	THD420L	11/32 (8,73)	3/16 (4,76)
KNHL420J							
KNH524J	0,453 (11,51)	0,510 (12,95)	1/2-13	0,50 (12,7)	THD524L	13/32 (10,32)	3/16 (4,76)
KNHL524J							

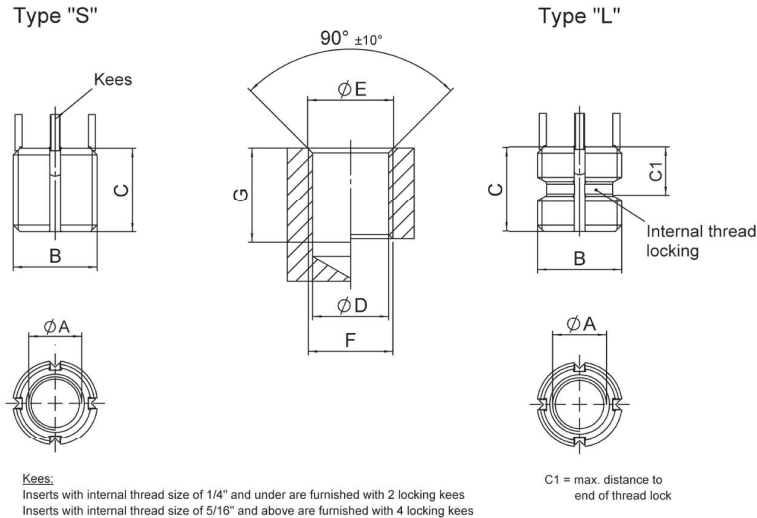

Part-no.		Dimensions				
Standard type "S"	Locking type "L"	Thread A Ø A class 3B	Thread B Ø B class 2A mod.	Shear engagement inch ² (mm ²)	C inch (mm)	C1 inch (mm)
KNH518J		5/16-18	1/2-13	0,3588 (231,5)	0,43 (10,9)	
	KNHL518J			0,2608 (168,3)		0,37 (9,40)
KNH624J		3/8-24	9/16-12	0,4975 (321,0)	0,50 (12,7)	
	KNHL624J			0,3843 (248,0)		0,37 (9,40)
KNH616J		3/8-16	9/16-12	0,4975 (321,0)	0,50 (12,7)	
	KNHL616J			0,3843 (248,0)		0,41 (10,41)
KNH720J		7/16-20	5/8-11	0,7172 (462,7)	0,62 (15,8)	
	KNHL720J			0,5831 (376,2)		0,42 (10,67)
KNH714J		7/16-14	5/8-11	0,7172 (462,7)	0,62 (15,8)	
	KNHL714J			0,5831 (376,2)		0,46 (11,68)

Part-no.	Installation dimensions					Removal dimensions	
	Ø D modified tap drill Ø inch	Ø E countersink Ø inch +0,01 (mm)	Thread F		Hand installation tool part-no.	Drill	
			Ø F class UNC-2B	G min. inch (mm)		Ø inch (mm)	Depth inch (mm)
KNH518J	0,453 (11,51)	0,510 (12,95)	1/2-13	0,50 (12,7)	THD518L	13/32 (10,32)	3/16 (4,76)
KNHL518J							
KNH624J	0,516 (13,11)	0,572 (14,53)	9/16-12	0,56 (14,2)	THD624L	15/32 (11,91)	3/16 (4,76)
KNHL624J							
KNH616J	0,516 (13,11)	0,572 (14,53)	9/16-12	0,56 (14,2)	THD616L	15/32 (11,91)	3/16 (4,76)
KNHL616J							
KNH720J	0,578 (14,68)	0,635 (16,13)	5/8-11	0,68 (17,27)	THD720L	17/32 (13,49)	3/16 (4,76)
KNHL720J							
KNH714J	0,578 (14,68)	0,635 (16,13)	5/8-11	0,68 (17,27)	THD714L	17/32 (13,49)	3/16 (4,76)
KNHL714J							

Type "S"

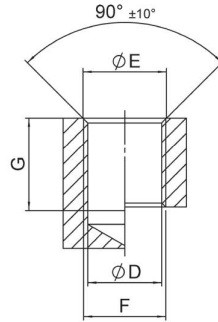
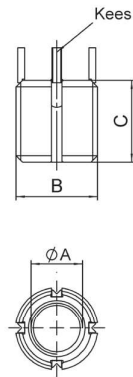

Type "L"

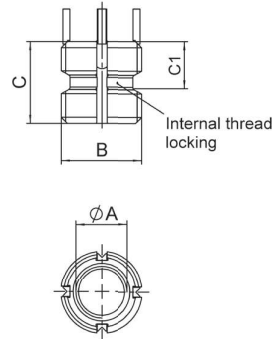

Kees:
Inserts with internal thread size of 1/4" and under are furnished with 2 locking kees
Inserts with internal thread size of 5/16" and above are furnished with 4 locking kees

C1 = max distance to end of thread lock

Part-no.		Dimensions				
Standard type "S"	Locking type "L"	Thread A Ø A class 3B	Thread B Ø B class 2A mod.	Shear engagement inch ² (mm ²)	C inch (mm)	C1 inch (mm)
KNH820J		1/2-20	11/16-11NS	0,8884 (573,2)	0,68 (17,3)	
	KNHL820J			0,7368 (475,4)		0,42 (10,67)
KNH813J		1/2-13	11/16-11NS	0,8884 (573,2)	0,68 (17,3)	
	KNHL813J			0,7368 (475,4)		0,47 (11,94)
KNH918J		9/16-18	13/16-16	1,2493 (806,0)	0,81 (20,6)	
	KNHL918J			1,0247 (661,1)		0,48 (12,19)
KNH912J		9/16-12	13/16-16	1,2493 (806,0)	0,81 (20,6)	
	KNHL912J			1,0247 (661,1)		0,54 (13,72)
KNH1018J		5/8-18	7/8-14	1,4866 (959,1)	0,87 (22,1)	
	KNHL1018J			1,2415 (801,0)		0,49 (12,47)
KNH1011J		5/8-11	7/8-14	1,4866 (959,1)	0,87 (22,1)	
	KNHL1011J			1,2415 (801,0)		0,57 (14,48)

Part-no.	Installation dimensions				Hand installation tool part-no.	Removal dimensions	
	Ø D modified tap drill Ø inch	Ø E countersink Ø inch +0,01 (mm)	Thread F			Drill	
			Ø F class UNC-2B	G min. inch (mm)		Ø inch (mm)	Depth inch (mm)
KNH820J	0,641 (16,28)	0,700 (17,80)	11/16-11NS	0,75 (19,06)	THD820L	19/32 (15,08)	3/16 (4,76)
KNHL820J							
KNH813J	0,641 (16,28)	0,700 (17,80)	11/16-11NS	0,75 (19,06)	THD813L	19/32 (15,08)	3/16 (4,76)
KNHL813J							
KNH918J	0,766 (19,46)	0,822 (20,88)	13/16-16UN	0,94 (23,88)	THD918L	23/32 (18,26)	3/16 (4,76)
KNHL918J							
KNH912J	0,766 (19,46)	0,822 (20,88)	13/16-16UN	0,94 (23,88)	THD912L	23/32 (18,26)	3/16 (4,76)
KNHL912J							
KNH1018J	0,828 (21,03)	0,885 (22,48)	7/8-14UNF	1,00 (25,40)	THD1018L	25/32 (19,84)	3/16 (4,76)
KNHL1018J							
KNH1011J	0,828 (21,03)	0,885 (22,48)	7/8-14 UNF	1,00 (25,40)	THD1011L	25/32 (19,84)	3/16 (4,76)
KNHL1011J							

Type "S"

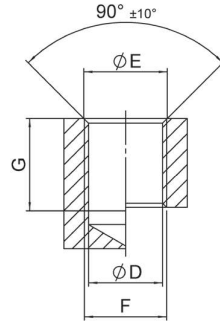
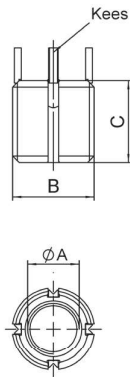

Type "L"

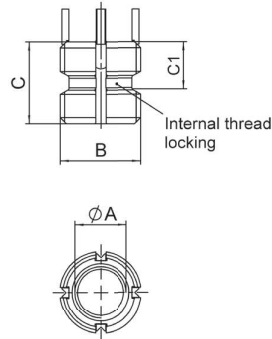

Kees:
Inserts with internal thread size of 1/4" and under are furnished with 2 locking kees
Inserts with internal thread size of 5/16" and above are furnished with 4 locking kees

C1 = max. distance to end of thread lock

Part-no.		Dimensions				
Standard type "S"	Locking type "L"	Thread A Ø A class 3B	Thread B Ø B class 2A mod.	Shear engagement inch ² (mm ²)	C inch (mm)	C1 inch (mm)
KNH1216J	KNHL1216J	3/4-16	1-1/8-12	2,4901 (1606,5)	1,12 (28,5)	0,68 (17,27)
				2,4478 (1579,3)	1,25 (31,8)	
KNH1210J	KNHL1210J	3/4-10	1-1/8-12	2,4901 (1606,5)	1,12 (28,5)	0,75 (19,05)
				2,4478 (1579,3)	1,25 (31,8)	
KNH1414J	KNHL1414J	7/8-14	1-1/4-12	3,1370 (2024,1)	1,25 (31,8)	0,69 (17,53)
				3,0775 (1985,6)	1,37 (34,8)	
KNH1409J	KNHL1409J	7/8-9	1-14/12	3,1370 (2024,1)	1,25 (31,8)	0,77 (19,56)
				3,0775 (1985,6)	1,37 (34,8)	
KNH1612J	KNHL1612J	1-12	1-3/8-12	3,8381 (2476,3)	1,37 (34,8)	0,78 (19,81)
				3,7929 (2447,2)	1,50 (38,1)	
KNH1608J	KNHL1608J	1-8	1-3/8-12	3,8381 (2476,3)	1,37 (34,8)	0,86 (21,84)
				3,7929 (2447,2)	1,50 (38,1)	

Part-no.	Installation dimensions				Hand installation tool part-no.	Removal dimensions	
	Ø D modified tap drill Ø inch	Ø E countersink Ø inch +0,01 (mm)	Thread F			Ø inch (mm)	Depth inch (mm)
			Ø F class UNC- 2B	G min. inch (mm)			
KNH1216J	1,062 (26,97)	1,145 (29,08)	1-1/8-12 UNF	1,31 (33,27) 1,44 (36,58)	THD1216L	31/32 (24,61)	5/16 (7,94)
KNHL1216J							
KNH1210J	1,062 (26,97)	1,145 (29,08)	1-1/8-12 UNF	1,31 (33,27) 1,44 (36,58)	THD1210L	31/32 (24,61)	5/16 (7,94)
KNHL1210J							
KNH1414J	1,187 (30,15)	1,270 (32,26)	1-1/4-12 UNF	1,44 (36,58) 1,56 (39,62)	THD1414L	1-3/32 (27,78)	5/16 (7,94)
KNHL1414J							
KNH1409J	1,187 (30,15)	1,270 (32,26)	1-1/4-12 UNF	1,44 (36,58) 1,56 (39,62)	THD1409L	1-3/32 (27,78)	5/16 (7,94)
KNHL1409J							
KNH1612J	1,312 (33,32)	1,395 (35,43)	1-3/8-12 UNF	1,56 (39,62) 1,68 (42,67)	THD1612L	1-7/32 (30,96)	5/16 (7,94)
KNHL1612J							
KNH1608J	1,312 (33,32)	1,395 (35,43)	1-3/8-12 UNF	1,56 (39,62) 1,68 (42,67)	THD1608L	1-7/32 (30,96)	5/16 (7,94)
KNHL1608J							

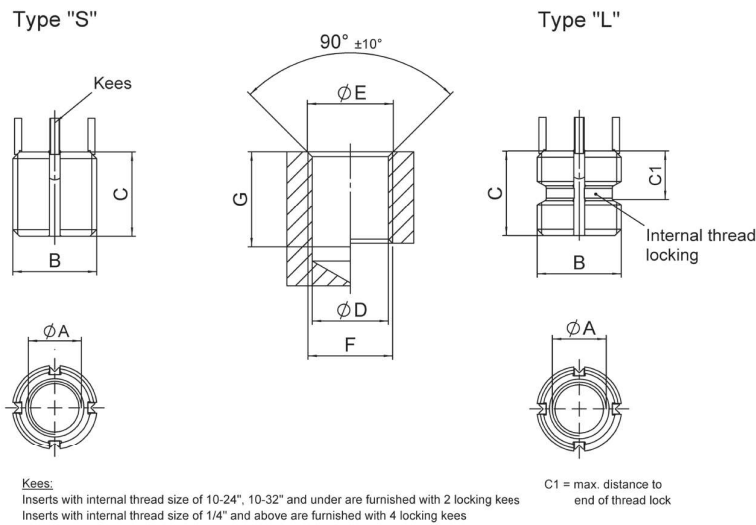

Part-no.		Dimensions				
Standard type "S"	Locking type "L"	Thread A Ø A class 3B	Thread B Ø B class 2A mod.	Shear engagement inch ² (mm ²)	C inch (mm)	C1 inch (mm)
KNHXH1032J		10-32	7/16-14	0,2299 (148,3)	0,31 (7,9)	
	KNHXHL1032J			0,1403 (90,5)		0,31 (7,90)
KNHXH1024J		10-24	7/16-14	0,2299 (148,3)	0,31 (7,9)	
	KNHXHL1024J			0,1403 (90,5)		0,31 (7,90)
KNHXH428J		1/4-28	1/2-13	0,2997 (193,4)	0,37 (9,4)	
	KNHXHL428J			0,2005 (129,4)		0,33 (8,38)
KNHXH420J		1/4-20	1/2-13	0,2997 (193,4)	0,37 (9,4)	
	KNHXHL420J			0,2005 (129,4)		0,36 (9,14)
KNHXH524J		5/16-24	9/16-12	0,4163 (268,6)	0,43 (10,9)	
	KNHXHL524J			0,3029 (195,4)		0,34 (8,64)

Part-no.	Installation dimensions					Removal dimensions	
	Ø D modified tap drill Ø inch	Ø E countersink Ø inch +0,01 (mm)	Thread F		Hand installation tool part-no.	Drill	
			Ø F class UNC- 2B	G min. inch (mm)		Ø inch (mm)	Depth inch (mm)
KNHXH1032J	0,397 (10,08)	0,447 (11,35)	7/16-14	0,37 (9,40)	THXHD1032L	11/32 (8,73)	3/16 (4,76)
KNHXHL1032J							
KNHXH1024J	0,397 (10,08)	0,447 (11,35)	7/16-14	0,37 (9,40)	THXHD1024L	11/32 (8,73)	3/16 (4,76)
KNHXHL1024J							
KNHXH428J	0,453 (11,51)	0,510 (12,95)	1/2-13	0,44 (11,18)	THXHD428L	13/32 (10,32)	3/16 (4,76)
KNHXHL428J							
KNHXH420J	0,453 (11,51)	0,510 (12,95)	1/2-13	0,44 (11,18)	THXHD420L	13/32 (10,32)	3/16 (4,76)
KNHXHL420J							
KNHXH524J	0,516 (13,11)	0,572 (14,53)	9/16-12	0,50 (12,70)	THXHD524L	15/32 (11,91)	3/16 (4,76)
KNHXHL524J							

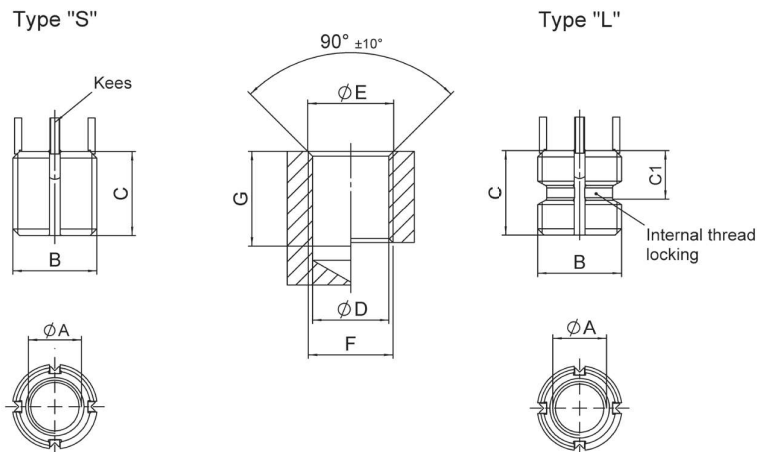

Kees:
Inserts with internal thread size of 10-24", 10-32" and under are furnished with 2 locking kees
Inserts with internal thread size of 1/4" and above are furnished with 4 locking kees

C1 = max. distance to end of thread lock

Part-no.		Dimensions				
Standard type "S"	Locking type "L"	Thread A Ø A class 3B	Thread B Ø B class 2A mod.	Shear engagement inch ² (mm ²)	C inch (mm)	C1 inch (mm)
KNHXH518J		5/16-18	9/16-12	0,4163 (268,6)	0,43 (10,9)	0,37 (9,40)
	KNHXHL518J			0,3029 (195,4)		
KNHXH624J		3/8-24	5/8-11	0,5584 (360,3)	0,50 (12,7)	0,37 (9,40)
	KNHXHL624J			0,4234 (273,8)		
KNHXH616J		3/8-16	5/8-11	0,5584 (360,3)	0,50 (12,7)	0,41 (10,41)
	KNHXHL616J			0,4234 (273,8)		
KNHXH720J		7/16-20	11/16-11 NS	0,8000 (516,1)	0,62 (15,6)	0,42 (10,67)
	KNHXHL720J			0,6498 (419,2)		
KNHXH714J		7/16-14	11/16-11 NS	0,8000 (516,1)	0,62 (15,6)	0,46 (11,68)
	KNHXHL714J			0,6498 (419,2)		

Part-no.	Installation dimensions					Removal dimensions	
	Ø D modified tap drill Ø inch	Ø E countersink Ø inch +0,01 (mm)	Thread F		Hand installation tool part-no.	Drill	
			Ø F class UNC- 2B	G min. inch (mm)		Ø inch (mm)	Depth inch (mm)
KNHXH518J	0,516 (13,11)	0,572 (14,53)	9/16-12	0,50 (12,70)	THXHD518L	15/32 (11,91)	3/16 (4,76)
KNHXHL518J							
KNHXH624J	0,578 (14,68)	0,635 (16,13)	5/8-11	0,56 (14,22)	THXHD624L	17/32 (13,49)	3/16 (4,76)
KNHXHL624J							
KNHXH616J	0,578 (14,68)	0,635 (16,13)	5/8-11	0,56 (14,22)	THXHD616L	17/32 (13,49)	3/16 (4,76)
KNHXHL616J							
KNHXH720J	0,641 (16,28)	0,700 (17,80)	11/16-11 NS	0,68 (17,27)	THXHD720L	19/32 (15,08)	3/16 (4,76)
KNHXHL720J							
KNHXH714J	0,641 (16,28)	0,700 (17,80)	11/16-11 NS	0,68 (17,27)	THXHD714L	19/32 (15,08)	3/16 (4,76)
KNHXHL714J							

Type "S"

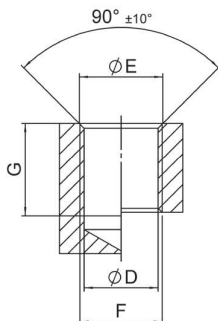
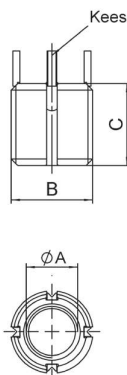

Type "L"

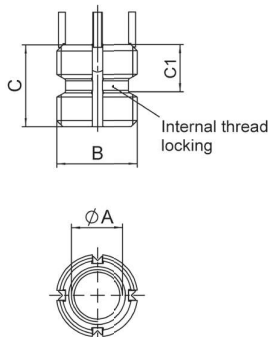

Kees:
Inserts with internal thread size of 10-24", 10-32" and under are furnished with 2 locking keys
Inserts with internal thread size of 1/4" and above are furnished with 4 locking keys

C1 = max. distance to end of thread lock

Part-no.		Dimensions				
Standard type "S"	Locking type "L"	Thread A Ø A class 3B	Thread B Ø B class 2A mod.	Shear engagement inch ² (mm ²)	C inch (mm)	C1 inch (mm)
KNHXH820J		1/2-20	13/16-16	1,0293 (664,1)	0,68 (17,3)	
	KNHXHL820J			0,8642 (557,6)		0,42 (10,67)
KNHXH813J		1/2-13	13/16-16	1,0293 (664,1)	0,68 (17,3)	
	KNHXHL813J			0,8642 (557,6)		0,47 (11,94)
KNHXH918J		9/16-18	7/8-14	1,3761 (887,8)	0,81 (20,6)	
	KNHXHL918J			1,1131 (718,1)		0,48 (12,19)
KNHXH912J		9/16-12	7/8-14	1,3761 (887,8)	0,81 (20,6)	
	KNHXHL912J			1,1131 (718,1)		0,54 (13,72)
KNHXH1018J		5/8-18	1-12	1,6420 (1059,4)	0,87 (22,1)	
	KNHXHL1018J			1,2770 (823,9)		0,51 (12,95)
KNHXH1011J		5/8-11	1-12	1,6420 (1059,4)	0,87 (22,1)	
	KNHXHL1011J			1,2770 (823,9)		0,59 (14,99)

Part-no.	Installation dimensions				Hand installation tool part-no.	Removal dimensions	
	Ø D modified tap drill Ø inch	Ø E countersink Ø inch +0,01 (mm)	Thread F			Drill	
			Ø F class UNC-2B	G min. inch (mm)		Ø inch (mm)	Depth inch (mm)
KNHXH820J	0,766 (19,46)	0,822 (20,88)	13/16-16 UNF	0,75 (19,05)	THXHD820L	23/32 (18,26)	3/16 (4,76)
KNHXHL820J							
KNHXH813J	0,766 (19,46)	0,822 (20,88)	13/16-16 UNF	0,75 (19,05)	THXHD813L	23/32 (18,26)	3/16 (4,76)
KNHXHL813J							
KNHXH918J	0,828 (21,03)	0,885 (22,48)	7/8-14 UNF	0,94 (23,88)	THXHD918L	25/32 (19,84)	3/16 (4,76)
KNHXHL918J							
KNHXH912J	0,828 (21,03)	0,885 (22,48)	7/8-14 UNF	0,94 (23,88)	THXHD912L	25/32 (19,84)	3/16 (4,76)
KNHXHL912J							
KNHXH1018J	0,937 (23,80)	1,020 (25,91)	1-12 UNF	1,00 (25,40)	THXHD1018L	27/32 (21,43)	5/16 (7,94)
KNHXHL1018J							
KNHXH1011J	0,937 (23,80)	1,020 (25,91)	1-12 UNF	1,00 (25,40)	THXHD1011L	27/32 (21,43)	5/16 (7,94)
KNHXHL1011J							

Type "S"

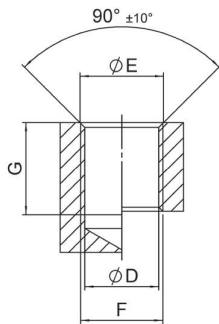
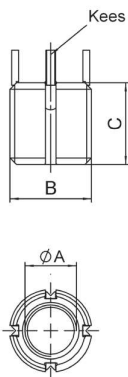

Type "L"

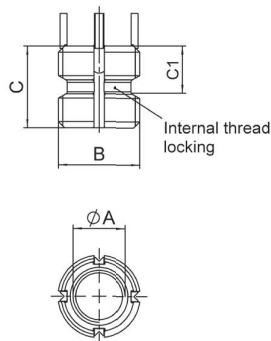

Kees:

Inserts with internal thread size of 10-24", 10-32" and under are furnished with 2 locking kees
Inserts with internal thread size of 1/4" and above are furnished with 4 locking kees

C1 = max. distance to end of thread lock

Part-no.		Dimensions				
Standard type "S"	Locking type "L"	Thread A Ø A class 3B	Thread B Ø B class 2A mod.	Shear engagement inch ² (mm ²)	C inch (mm)	C1 inch (mm)
KNHXH1216J		3/4-16	1-1/4-12	2,7966 (1804,2)	1,12 (28,5)	
	KNHXHL1216J			2,5505 (1645,5)	1,25 (31,8)	0,57 (14,48)
KNHXH1210J		3/4-10	1-1/4-12	2,7966 (1804,2)	1,12 (28,5)	
	KNHXHL1210J			2,5505 (1645,5)	1,25 (31,8)	0,64 (16,26)
KNHXH1414J		7/8-14	1-3/8-12	3,4652 (2235,6)	1,25 (31,8)	
	KNHXHL1414J			3,2769 (2114,1)	1,37 (34,8)	0,63 (16,00)
KNHXH1409J		7/8-9	1-3/8-12	3,4652 (2235,6)	1,25 (31,8)	
	KNHXHL1409J			3,2769 (2114,1)	1,37 (34,8)	0,71 (18,03)
KNHXH1612J		1-12	1-1/2-12	4,2374 (2733,8)	1,37 (34,8)	
	KNHXHL1612J			4,2135 (2718,4)	1,50 (38,1)	0,70 (17,78)
KNHXH1608J		1-8	1-1/2-12	4,2374 (2733,8)	1,37 (34,8)	
	KNHXHL1608J			4,2135 (2718,4)	1,50 (38,1)	0,78 (19,81)

Part-no.	Installation dimensions				Hand installation tool part-no.	Removal dimensions	
	Ø D modified tap drill Ø inch	Ø E countersink Ø inch +0,01 (mm)	Thread F			Ø inch (mm)	Depth inch (mm)
			Ø F class UNC-2B	G min. inch (mm)			
KNHXH1216J	1,187 (30,15)	1,270 (32,26)	1-1/4-12 UNF	1,31 (33,27)	THXHD1216L	1-3/32 (27,78)	5/16 (7,94)
KNHXHL1216J				1,44 (36,58)			
KNHXH1210J	1,187 (30,15)	1,270 (32,26)	1-1/4-12 UNF	1,31 (33,27)	THXHD1210L	1-3/32 (27,78)	5/16 (7,94)
KNHXHL1210J				1,44 (36,58)			
KNHXH1414J	1,312 (33,32)	1,395 (35,43)	1-3/8-12 UNF	1,44 (36,58)	THXHD1414L	1-7/32 (30,96)	5/16 (7,94)
KNHXHL1414J				1,56 (39,62)			
KNHXH1409J	1,312 (33,32)	1,395 (35,43)	1-3/8-12 UNF	1,44 (36,58)	THXHD1409L	1-7/32 (30,96)	5/16 (7,94)
KNHXHL1409J				1,56 (39,62)			
KNHXH1612J	1,437 (36,50)	1,520 (38,61)	1-1/2-12 UNF	1,56 (39,62)	THXHD1612L	1-11/32 (34,13)	5/16 (7,94)
KNHXHL1612J				1,38 (42,67)			
KNHXH1608J	1,437 (36,50)	1,520 (38,61)	1-1/2-12 UNF	1,56 (39,62)	THXHD1608L	1-11/32 (34,13)	5/16 (7,94)
KNHXHL1608J				1,38 (42,67)			



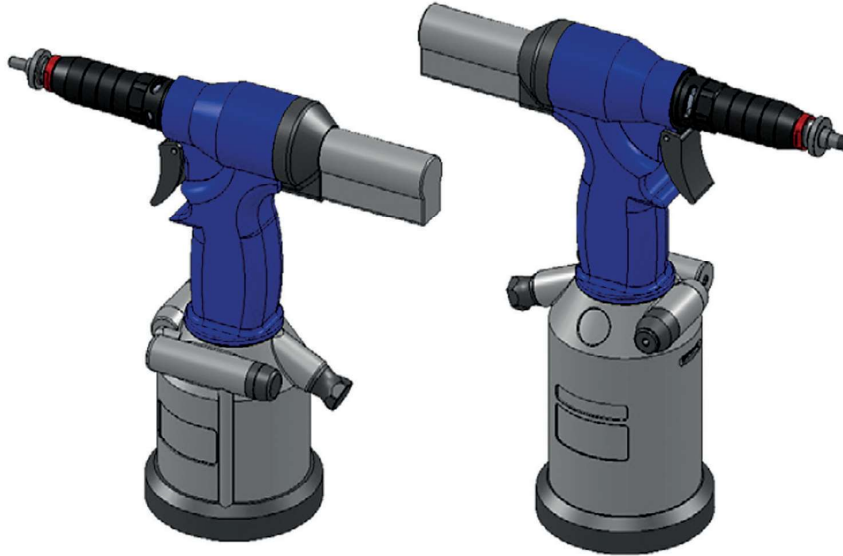

HYDRO-PNEUMATIC TOOLS FOR **KEENSERTS®**

Features

- The hydro-pneumatic Power Tool 3352PTC-1 is designed to install metric **KEENSERTS®** from sizes M5 to M12 and imperial sizes from 1032/1024 to 8137820. The slightly bigger 3352PTC-2 has a larger stroke to install M5 to M24 sized metric **KEENSERTS®**. For each size of **KEENSERTS®** a specific nose piece is required.
- Individual adjustments can be made using the integrated force control depending on size of the **KEENSERTS®** and hardness of the surrounding material.
- Due to the one-button operation it is easy to operate. The installation is quick, consistent and reliable.
- The hydro-pneumatic system is low maintenance, ergonomic and lightweight.
- Please note: Next to the Power Tool an appropriate nose piece for each size of **KEENSERTS®** has to be ordered separately.
- Of Course the nosepieces are also compatible with the E-Drive Power Tool EPT1.

Click here:

[KEENSERTS® Power Tool 3352 – The simple way of KEENSERTS®-installation](#) (Youtubelink)



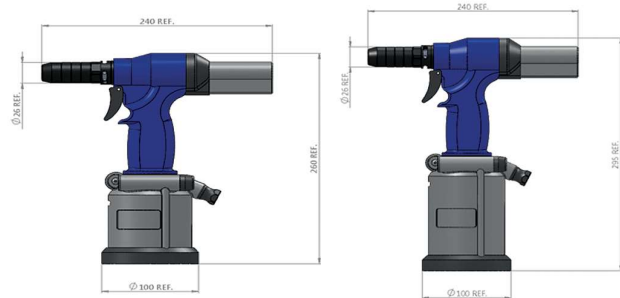

Technical Data

Tool	3352PT1	3352PT2
Air working pressure	6 bar / 90 PSI	6 bar / 90 PSI
Min. – Max. air pressure	5 - 7 bar / 70 - 100 PSI	5 - 7 bar / 70 - 100 PSI
Air consumption per cycle at 6 bar	5 Liter / 1.3 gallons	5 Liter / 1.3 gallons
Max. stroke	6.5 mm / 0.26 inch	8 mm / 0.31 inch
Max. force	19,000 N / 4,300 lbf	19,000 N / 4,300 lbf
Weight (without nosepiece)	1.800 Kg / 4 pounds	2.200 Kg / 4.85 pounds
Vibrations	< 2.5 m/s ² / 8.2 ft/s ²	< 2.5 m/s ² / 8.2 ft/s ²
Noise Level	76 dB (A)	76 dB (A)

Standard Accessoires

Ref.	Code	Qty.	Description
1	3352PTC-1 or 3352PTC-2	1	Power Tool complete, consists of:
	3352PT1 or 3352PT2	1	Power Tool
2	3352-3064400	1	Oil Bottle (Type ISO VG 32 100CC)
3	3352-1010	1	Plastic Tool Case
4	3352-0207300	1	Tool Wrench
5	3352-2533800	1	Removal Bolt
6	3352-4154200	1	Allen Wrench 3,0mm
	MNL-3352-1	1	Instruction Manual
	MNL-3352-2	1	Installation Manual

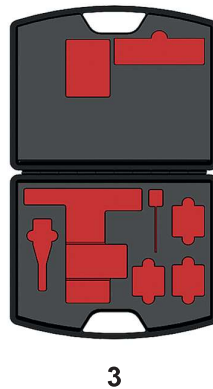
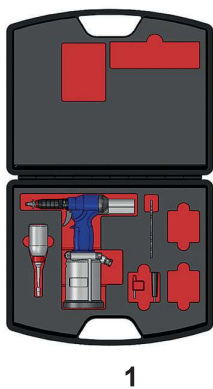

Nosepieces < M12

The Power Tools 3352PTC-1 and 3352PTC-2 comes without nosepieces, these have to be ordered separately according to the users needs.

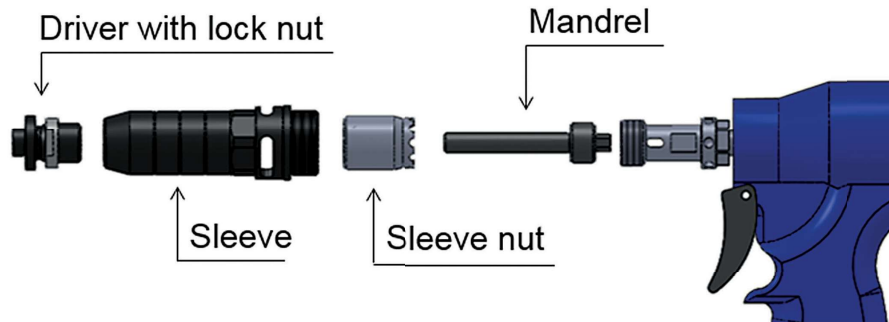

Mandrel, Driver and Lock Nut are part of the nose piece set for KEENSERTS® <M12

The nosepieces are a modular 3 piece design meaning next to the nosepiece set each component is available as an individual part. The customer can transform a nosepiece for a regular KEENSERTS® into a heavy type nose piece by just buying and replacing one part.









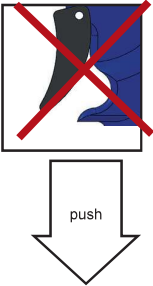

Nosepieces > M12

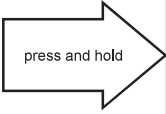
Metric nosepieces from M16 to M24 are designed differently and sold as a set only.

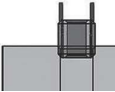

Installation Procedure

Step 1	Step 2	Step 3	Step 4	Step 5
<p>Screw in the KEENSERTS® by hand for about one to two turns.</p>	<p>Push the outer thread of the mandrel into the inner thread of the KEENSERTS®. The screw-in process will start automatically activated by the pushing force.</p>	<p>Do not press the trigger yet. The screw-in operation stops automatically once the insert reaches its final position (when the thicker part of the Kees touch the countersunk surface).</p>	<p>Then push the trigger for Kees to be pressed in.</p>	<p>Keep the trigger pressed, after the Kees are pressed in the mandrel will rotate counterclockwise until it gets out of the KEENSERTS®. Then release the trigger.</p>
				
				

Available metric Nosepieces



KEENSERTS® Size	Nosepiece Set	Spare Part Mandrel	Spare Part Driver	Spare Part Lock Nut
----------------------------	----------------------	---------------------------	------------------------------	--------------------------------

KNM Serie

KNM(L)5x0.8	3352TM5x0.8AY	3352S04M5x0.8BY	3352S05M5AY	3352S03-1AY
KNM(L)6x1.0	3352TM6x1.0AY	3352S04M6x1.0BY	3352S05M6AY	
KNM(L)8x1.25	3352TM8x1.25AY	3352S04M8x1.25BY	3352S05M8AY	
KNM(L)10x1.5	3352TM10x1.5AY	3352S04M10x1.5BY	3352S05M10AY	
KNM(L)12x1.75	3352TM12x1.75AY	3352S04M12x1.75BY	3352S05M12AY	

KNHM Series

KNHM(L)5x0.8	3352THM5x0.8AY	3352S04M5x0.8BY	3352S05HM5AY	3352S03-1AY
KNHM(L)6x1.0	3352THM6x1.0AY	3352S04M6x1.0BY	3352S05HM6AY	
KNHM(L)8x1.25	3352THM8x1.25AY	3352S04M8x1.25BY	3352S05HM8AY	
KNHM(L)10x1.5	3352THM10x1.5AY	3352S04M10x1.5BY	3352S05HM10AY	
KNHM(L)12x1.75	3352THM12x1.75AY	3352S04M12x1.75BY	3352S05HM12AY	

**KNHM Series heavy duty Nosepieces
(3352PTC-2 required)**



KNHM16x2.0	3352THM16x2.0AY	Available as set only
KNHM18x1.5	3352THM18x1.5AY	
KNHM20x2.5	3352THM20x2.5AY	
KNHM24x3.0	3352THM24x3.0AY	

Available imperial Nosepieces



KEENSERTS® size	Nosepiece Set	Spare Part Mandrel	Spare Part Driver	Spare Part Lock Nut
------------------------	----------------------	---------------------------	--------------------------	----------------------------

KNJ Serie

KN(L)1032J	3352T1032AY	3352S01-1032BY	3352S02-10AY	3352S03-1AY
KN(L)1024J	3352T1024AY	3352S01-1024BY		
KN(L)428J	3352T428AY	3352S01-428BY	3352S02-1/4AY	
KN(L)420J	3352T420AY	3352S01-420BY		
KN(L)524J	3352T524AY	3352S01-524BY	3352S02-5/16AY	
KN(L)518J	3352T518AY	3352S01-518BY		
KN(L)624J	3352T624AY	3352S01-624BY	3352S02-3/8AY	
KN(L)616J	3352T616AY	3352S01-616BY		
KN(L)720J	3352T720AY	3352S01-720BY	3352S02-7/16AY	
KN(L)714J	3352T714AY	3352S01-714BY		
KN(L)820J	3352T820AY	3350S01-820BY	3352S02-1/2AY	
KN(L)813J	3352T813AY	3352S01-813BY		

KNHJ Series

KNH(L)1032J	3352TH1032AY	3352S01-1032BY	3352S02-H10AY	3352S03-1AY
KNH(L)1024J	3352TH1024AY	3352S01-1024BY		
KNH(L)428J	3352TH428AY	3352S01-428BY	3352S02-H1/4AY	
KNH(L)420J	3352TH420AY	3352S01-420BY		
KNH(L)524J	3352TH524AY	3352S01-524BY	3352S02-H5/16AY	
KNH(L)518J	3352TH518AY	3352S01-518BY		
KNH(L)624J	3352TH624AY	3352S01-624BY	3352S02-H3/8AY	
KNH(L)616J	3352TH616AY	3352S01-616BY		
KNH(L)720J	3352TH720AY	3352S01-720BY	3352S02-H7/16AY	
KNH(L)714J	3352TH714AY	3352S01-714BY		
KNH(L)820J	3352TH820AY	3352S01-820BY	3352S02-H1/2AY	
KNH(L)813J	3352TH813AY	3352S01-813BY		

KEENSERTS®

Hand Tools

KNT Series



Introducing the new KNT line of KEENSERTS® Hand Tools

Next to a fast and easy installation a save, repeatable and reliable installation process, even for untrained personnel, was on the agenda for this new line of tools.

This was realized with a tool working on the telescopic principle that gives an excellent guidance during installation. Any titling of the tool that could result in bending or breaking of the kees is eliminated.

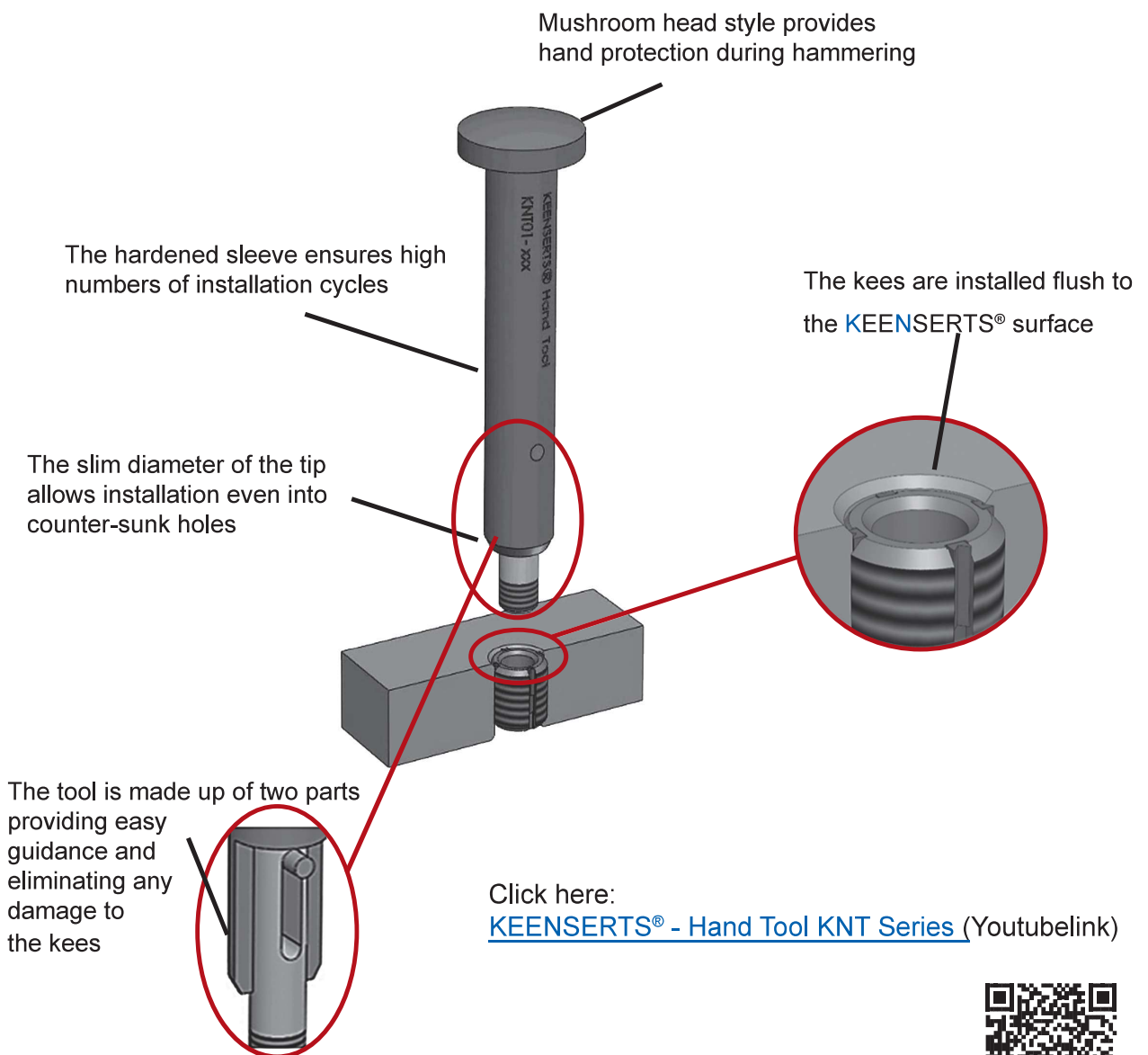

Installation Process

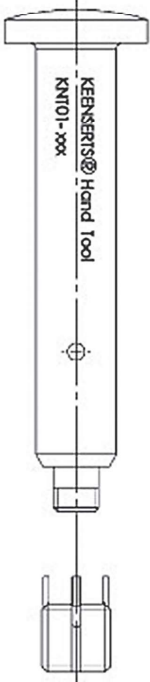
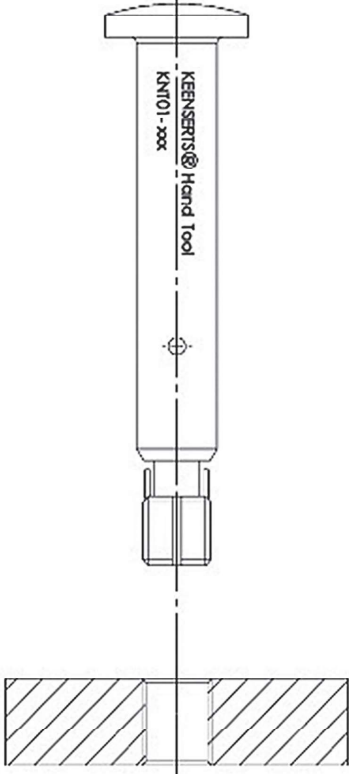
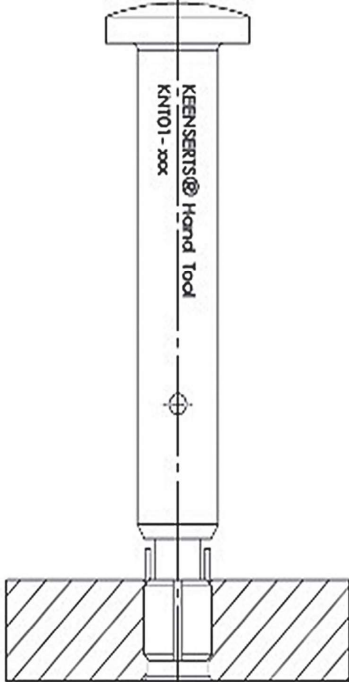
Step 1	Step 2	Step 3
<p data-bbox="191 548 532 642">Screw in the KEENSERTS® onto the threaded pin up to the end of the thread.</p> 	<p data-bbox="581 548 938 743">Screw the KEENSERTS® into the workpiece until the keys stop on the chamfer or the favored depth is reached (recommended hole preparation).</p> 	<p data-bbox="990 548 1386 743">Drive in the keys with short and precise hammer taps. Keys can be controlled after each tap until the favored depth is reached or until the anvil stops on the chamfer (final position).</p> 

Available Tool sizes

KEENSERTS® Size	Part Number
-----------------	-------------

KNT01

KNHM(L)4X0.7	KNT01-HM4x0.7AU
KNM(L)5X0.8	KNT01-M5x0.8AU
KNHM(L)5X0.8	KNT01-HM5x0.8AU
KNM(L)6X1.0	KNT01-M6x1.0AU
KNHM(L)6X1.0	KNT01-HM6x1.0AU
KNM(L)8X1.25	KNT01-M8x1.25AU
KNHM(L)8X1.25	KNT01-HM8x1.25AU
KNM(L)10X1.5	KNT01-M10x1.5AU
KNHM(L)10X1.5	KNT01-HM10x1.5AU
KNM(L)12X1.75	KNT01-M12x1.75AU
KNHM(L)12X1.75	KNT01-HM12x1.75AU

KNT03

KNHM(L)14x2.0	KNT03-HM14x2.0AU
KNHM(L)16x2.0	KNT03-HM16x2.0AU
KNHM(L)18x1.5	KNT03-HM18x1.5AU
KNHM(L)20x2.5	KNT03-HM20x2.5AU
KNHM(L)24x3.0	KNT03-HM24x3.0AU





KEENSERTS® EPT1 POWER TOOL
BATTERY DRIVEN POWER TOOL FOR CAMLOC® KEENSERTS® INSERTS

Features

- The battery driven Power Tool EPT1 installs metric KEENSERTS® from size M5 to M12 and imperial sizes from 10-32 (10-24) to ½-20 (½-13).
- Portable tool to make installation easy in any environment.
- It is easy to operate due to the one-trigger operation.
- The installation is quick, consistent and reliable.
- The battery powered system is low maintenance, ergonomic and lightweight.
- Individual adjustments can be made using the integrated force control directly via the tool's display.
- Individual language selection via the tool's display.
- Please note: The package includes the Power Tool EPT1, two rechargeable batteries, a charger, a tool wrench and the installation manual.
- An appropriate nosepiece for each size of KEENSERTS® must be ordered separately.
- All nosepieces are compatible with the hydropneumatic KEENSERTS® Power Tool 3352PT1 and 3352PT2.
- For more information please contact Camloc.

Installation video:



Technical Data

Tool	EPT1
Setting Force (Min - Max)	3.0 - 22.0 kN
Max. Spindle Stroke	7.0 mm / 0.276 inch
Tool Weight (without nosepiece)	2.1 Kg / 4.63 Pounds
Battery Weight	0.3 Kg / 0.66 Pounds
Battery	Li-Ion / 14.4 V / 2.6 Ah
Vibrations	< 0.672 m/s ² / < 2.1 ft/s ²
Sound Pressure Level LpA	71.7 dB (A)
Sound Power Level LwA	82.1 dB (A)
Temperature range	5°C - 40°C

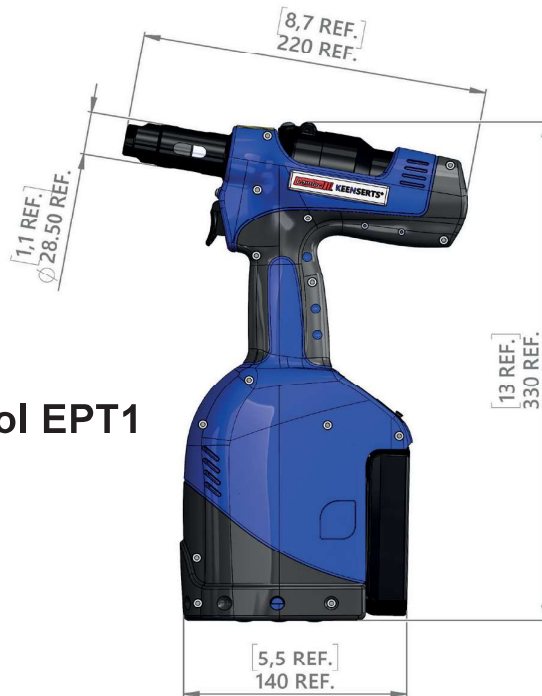

Scope of delivery of the Power Tool EPT1



Tool



Tool Wrench



Two Batteries



Charging Station



Tool Case

Nosepiece

The KEENSERTS® battery driven Power Tool EPT1 is delivered without nosepieces. The appropriate nosepiece must be ordered separately according to the users needs.

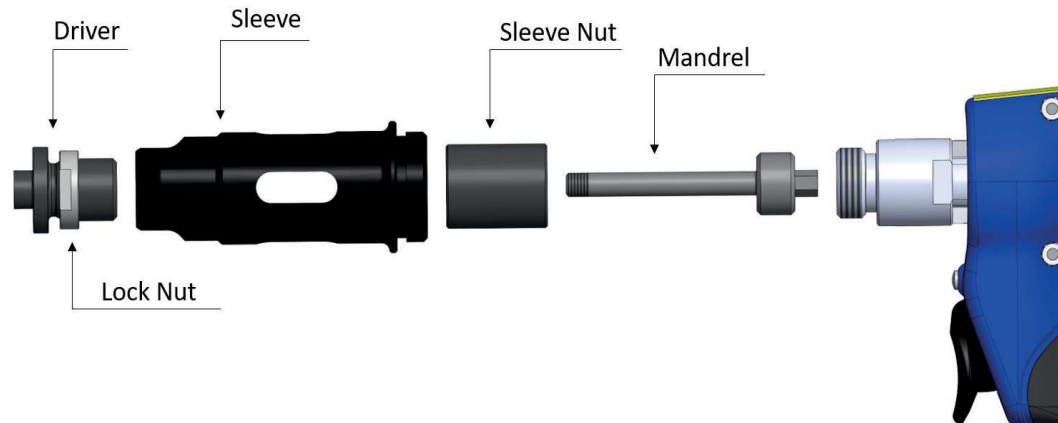

Mandrel, Driver and Lock Nut are components of the nosepiece set for KEENSERTS® installation.







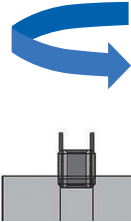
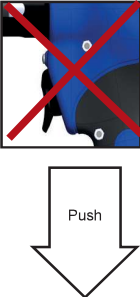

Each component of the nosepiece is available as an individual spare part. In addition to a simplified spare parts order, you can reduce your inventory by using multiple components.

For example, for KEENSERTS® of type KNM6, as well as KNHM6, the same mandrel and lock nut can be used. Only a different driver is required.

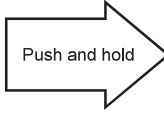
The same nosepiece can also be used for the self-locking version (locking type).

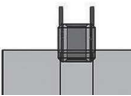

Installation procedure

Step 1	Step 2	Step 3	Step 4	Step 5
<p>Screw in the KEENSERTS® by hand for one to two turns.</p>	<p>Push the outer thread of the mandrel into the inner thread of the KEENSERTS®. The screw-in process will start automatically. Do not press the trigger yet!</p>	<p>The screw-in operation stops automatically once the insert reaches its final position (when the thicker part of the Kees touches the countersunk surface).</p>	<p>Press the trigger for the Kees to be installed.</p>	<p>Keep the trigger pressed. After the Kees are pressed in, the mandrel will rotate counter-clockwise until it has fully unscrewed from the KEENSERTS®. Finally, release the trigger.</p>
				
				

Available metric nosepieces



Part number				
KEENSERTS® size	Nosepiece Set	Spare part mandrel	Spare part driver	Spare part lock nut

KNM Series

KNM(L)5x0.8	3352TM5x0.8AY	3352S04M5x0.8BY	3352S05M5AY	3352S03-1AY
KNM(L)6x1.0	3352TM6x1.0AY	3352S04M6x1.0BY	3352S05M6AY	
KNM(L)8x1.25	3352TM8x1.25AY	3352S04M8x1.25BY	3352S05M8AY	
KNM(L)10x1.5	3352TM10x1.5AY	3352S04M10x1.5BY	3352S05M10AY	
KNM(L)12x1.75	3352TM12x1.75AY	3352S04M12x1.75BY	3352S05M12AY	

KNHM Series

KNHM(L)5x0.8	3352THM5x0.8AY	3352S04M5x0.8BY	3352S05HM5AY	3352S03-1AY
KNHM(L)6x1.0	3352THM6x1.0AY	3352S04M6x1.0BY	3352S05HM6AY	
KNHM(L)8x1.25	3352THM8x1.25AY	3352S04M8x1.25BY	3352S05HM8AY	
KNHM(L)10x1.5	3352THM10x1.5AY	3352S04M10x1.5BY	3352S05HM10AY	
KNHM(L)12x1.75	3352THM12x1.75AY	3352S04M12x1.75BY	3352S05HM12AY	

Available imperial nosepieces



Part number				
KEENSERTS® Size	Nosepiece Set	Spare part mandrel	Spare part driver	spare part lock nut

KNJ Series

KN(L)1032J	3352T1032AY	3352S01-1032BY	3352S02-10AY	3352S03-1AY
KN(L)1024J	3352T1024AY	3352S01-1024BY		
KN(L)428J	3352T428AY	3352S01-428BY	3352S02-1/4AY	
KN(L)420J	3352T420AY	3352S01-420BY		
KN(L)524J	3352T524AY	3352S01-524BY	3352S02-5/16AY	
KN(L)518J	3352T518AY	3352S01-518BY		
KN(L)624J	3352T624AY	3352S01-624BY	3352S02-3/8AY	
KN(L)616J	3352T616AY	3352S01-616BY		
KN(L)720J	3352T720AY	3352S01-720BY	3352S02-7/16AY	
KN(L)714J	3352T714AY	3352S01-714BY		
KN(L)820J	3352T820AY	3352S01-820BY	3352S02-1/2AY	
KN(L)813J	3352T813AY	3352S01-813BY		

KNHJ Series

KNH(L)1032J	3352TH1032AY	3352S01-1032BY	3352S02-H10AY	3352S03-1AY
KNH(L)1024J	3352TH1024AY	3352S01-1024BY		
KNH(L)428J	3352TH428AY	3352S01-428BY	3352S02-H1/4AY	
KNH(L)420J	3352TH420AY	3352S01-420BY		
KNH(L)524J	3352TH524AY	3352S01-524BY	3352S02-H5/16AY	
KNH(L)518J	3352TH518AY	3352S01-518BY		
KNH(L)624J	3352TH624AY	3352S01-624BY	3352S02-H3/8AY	
KNH(L)616J	3352TH616AY	3352S01-616BY		
KNH(L)720J	3352TH720AY	3352S01-720BY	3352S02-H7/16AY	
KNH(L)714J	3352TH714AY	3352S01-714BY		
KNH(L)820J	3352TH820AY	3352S01-820BY	3352S02-H1/2AY	
KNH(L)813J	3352TH813AY	3352S01-813BY		